



NEW JERSEY CENTER
FOR TEACHING & LEARNING

PSI[®]

Progressive Science Initiative[®]

This material is made freely available at www.njctl.org and is intended for the non-commercial use of students and teachers. It may not be used for any commercial purpose without the written permission of NJCTL.

We, at the New Jersey Education Association, are proud founders and supporters of NJCTL, an independent non-profit organization with the mission of empowering teachers to lead school improvement for the benefit of all students.





NEW JERSEY CENTER
FOR TEACHING & LEARNING

AP Physics 1

AP Physics 2

Electric Current & DC Circuits

2017-07-26

www.njctl.org

Electric Current & DC Circuits

Click on the topic to go to that section

- **Circuits**
- **Conductors**
- **Resistivity and Resistance**
- **Circuit Diagrams**
- **Measurement**
- **EMF & Terminal Voltage**
- **Kirchhoff's Rules**
- **Capacitors***
- **RC Circuits***

***These chapters are part of the AP 2, but not the AP 1 Curriculum.**

Circuits

[Return to
Table of
Contents](#)

Electric Current

Electric Current is the rate of flow of electric charges (charge carriers) through space. More specifically, it is defined as the amount of charge that flows past a location in a material per unit time. The letter "I" is the symbol for current.

$$I = \frac{\Delta Q}{\Delta t}$$

ΔQ is the amount of charge, and Δt is the time it flowed past the location.

The current depends on the type of material and the Electric Potential difference (voltage) across it.

Electric Current

A good analogy to help understand Electric Current is to consider water flow. The flow of water molecules is similar to the flow of electrons (the charge carriers) in a wire.

Water flow depends on the pressure exerted on the molecules either by a pump or by a height difference, such as water falling off a cliff.

Electric current depends on the "pressure" exerted by the Electric Potential difference - the greater the Electric Potential difference, the greater the Electric Current.

Electric Current

The current, $I = \frac{\Delta Q}{\Delta t}$ has the units Coulombs per second.

The units can be rewritten as Amperes (A).

$$1 \text{ A} = 1 \text{ C/s}$$

Amperes are often called "amps".

Electric Current

We know that if an Electric Potential difference is applied to a wire, charges will flow from high to low potential - a current.

However, due to a convention set by Benjamin Franklin, current in a wire is defined as the movement of positive charges (not the electrons which are really moving) and is called "conventional current."

Benjamin Franklin didn't do this to confuse future generations of electrical engineers and students. It was already known that electrical phenomena came in two flavors - attractive and repulsive - Franklin was the person who explained them as distinct positive and negative charges.

Electric Current

He arbitrarily assigned a positive charge to a glass rod that had been rubbed with silk. He could just as easily called it negative - 50/50 chance.

The glass rod was later found to have a shortage of electrons (they were transferred to the silk). So if the glass rod is grounded, the electrons will flow from the ground to the rod.

The problem comes in how Electric Potential is defined - charge carriers will be driven from high to low potential - from positive to negative. For this to occur in the glass rod - ground system, the conventional current will flow from the rod to the ground - opposite the direction of the movement of electrons.

Electric Current

To summarize - conventional Electric Current is defined as the movement of positive charge. In wires, it is opposite to the direction of the electron movement.

However - in the case of a particle accelerator, where electrons are stripped off of an atom, resulting in a positively charged ion, which is then accelerated to strike a target - the direction of the conventional current is the same as the direction of the positive ions!

Circuits

An electric circuit is an external path that charges can follow between two terminals using a conducting material.

For charge to flow, the path must be complete and unbroken.

An example of a conductor used to form a circuit is copper wire. Continuing the water analogy, one can think of a wire as a pipe for charge to move through.

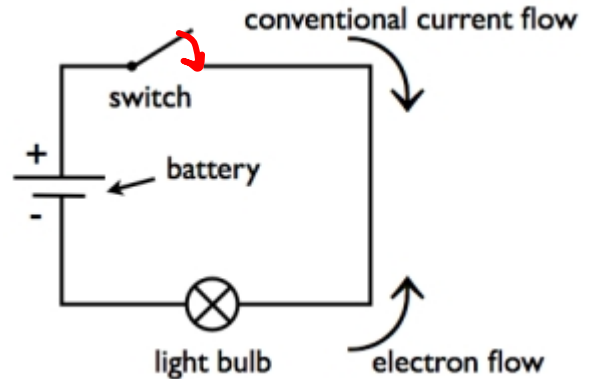

1 12 C of charge passes a location in a circuit in 10 seconds. What is the current flowing past the point?

1.2 A

3.3 A

4.8 A

5.0 A

I need help

2 A circuit has 3 A of current. How long does it take 45 C of charge to travel through the circuit?

A 3 s

B 5 s

C 15 s

D 20 s

E I need help

3 A circuit has 2.5 A of current. How much charge travels through the circuit after 4s?

A 2 C

B 4 C

C 8 C

D 10 C

E I need help

Batteries

Each battery has two terminals which are conductors. The terminals are used to connect an external circuit allowing the movement of charge.

Batteries convert chemical energy to electrical energy which maintains the potential difference.

The chemical reaction acts like an escalator, carrying charge up to a higher voltage.



[Click here for a Battery Voltage Simulation from PhET](#)

Reviewing Basic Circuits

The circuit cannot have gaps.

The bulb had to be between the wire and the terminal.

A voltage difference is needed to make the bulb light.

The bulb still lights regardless of which side of the battery you place it on.

As you watch the video, be ready to answer the below questions:

What is going on in the circuit?

What is the role of the battery?

How are the circuits similar? different?

Click here for
video using the
circuit simulator
from PhET

Batteries and Current

The battery pushes current through the circuit. A battery acts like a pump, pushing charge through the circuit. It is the circuit's energy source.

Charges do not experience an electrical force unless there is a difference in electrical potential (voltage). Therefore, batteries have a potential difference between their terminals. The positive terminal is at a higher voltage than the negative terminal.

[click here for a video from Veritasium's Derek on current](#)

How did the voltage affect current?

The greater the voltage, the greater the current.

Conductors

[Return to
Table of
Contents](#)

Conductors

Some conductors "conduct" better or worse than others. Reminder: conducting means a material allows for the free flow of electrons.

The flow of electrons is just another name for current. Another way to look at it is that some conductors resist current to a greater or lesser extent.

We call this resistance, R . Resistance is measured in ohms which is noted by the Greek symbol omega (Ω)

How will resistance affect current?

[Click here to run another PhET simulation](#)

Current vs Resistance & Voltage

Raising resistance reduces current and raising voltage increases current.

We can combine these relationships in what is named "**Ohm's Law**":

$$I = \frac{V}{R}$$

The units for Ohm's Law are Amperes (A): $A = \frac{V}{\Omega}$

Solving Ohm's Law for Resistance or Voltage

$$R = \frac{V}{I} \quad \text{OR} \quad V = IR$$

[click here for a Veritasium music video on electricity](#)

Current vs Resistance & Voltage

Raising resistance reduces current and raising voltage increases current. However, this relationship is linear in only what we call Ohmic materials. If the relationship is not linear, it is a non-Ohmic material.

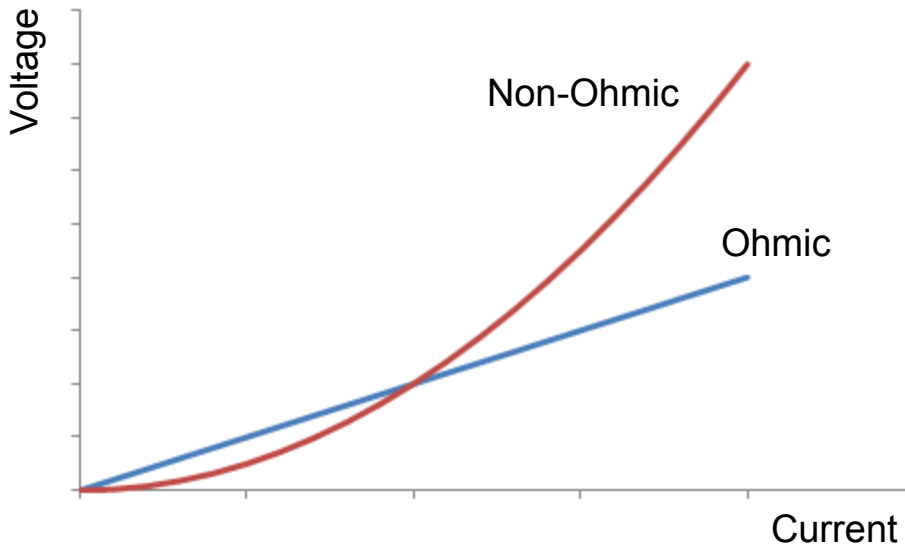

4 A flashlight has a resistance of 25Ω and is connected by a wire to a 120 V source of voltage. What is the current in the flashlight?

A 3.2 A

B 4.8 A

C 5.5 A

D 7.1 A

E I need help

5 How much voltage is needed in order to produce a 0.70 A current through a 490 Ω resistor?

- A 114 V
- B 267 V
- C 343 V
- D 408 V
- E I need help

6 What is the resistance of a rheostat coil, if 0.05 A of current flows through it when 6 V is applied across it?

120 Ω

220 Ω

240 Ω

310 Ω

I need help

Electrical Power

Power is defined as work per unit time

$$P = \frac{W}{t}$$

And we know

$$W = QV$$

Substitute QV into the
power equation for W

$$P = \frac{QV}{t}$$

We also know

$$I = \frac{Q}{t}$$

Substitute I into the power equation for $\frac{Q}{t}$

$$P = IV$$

What happens if the current is increased?

What happens if the voltage is decreased?

Electrical Power

Let's think about this another way...

The water at the top has GPE & KE.

As the water falls, it loses GPE and the wheel gets turned, doing work. When the water falls to the bottom it is now slower, having done work.

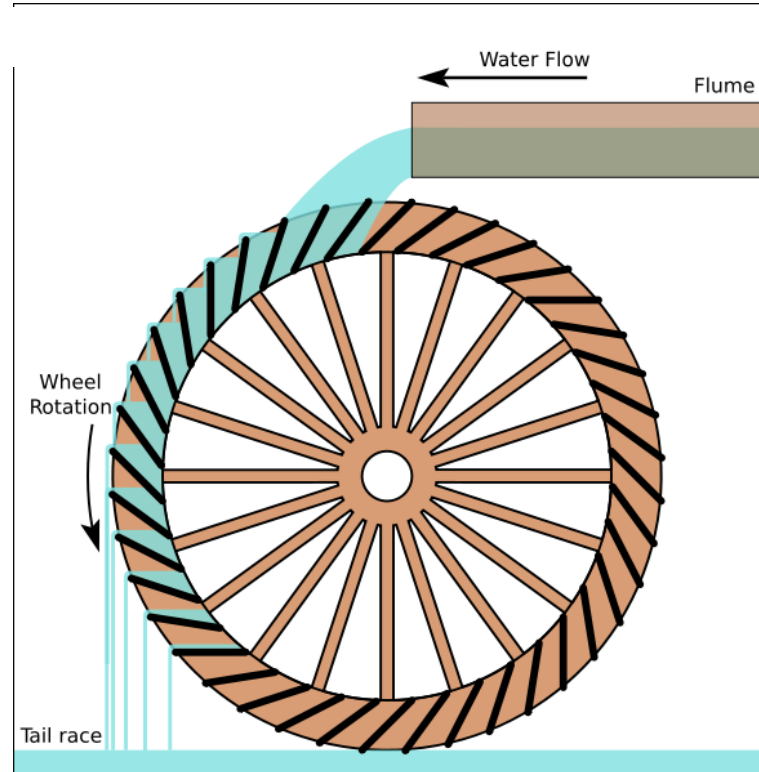

Electrical Power

Electric circuits are similar.

A charge falls from high voltage to low voltage.

In the process of falling energy may be used (light bulb, run a motor, etc).

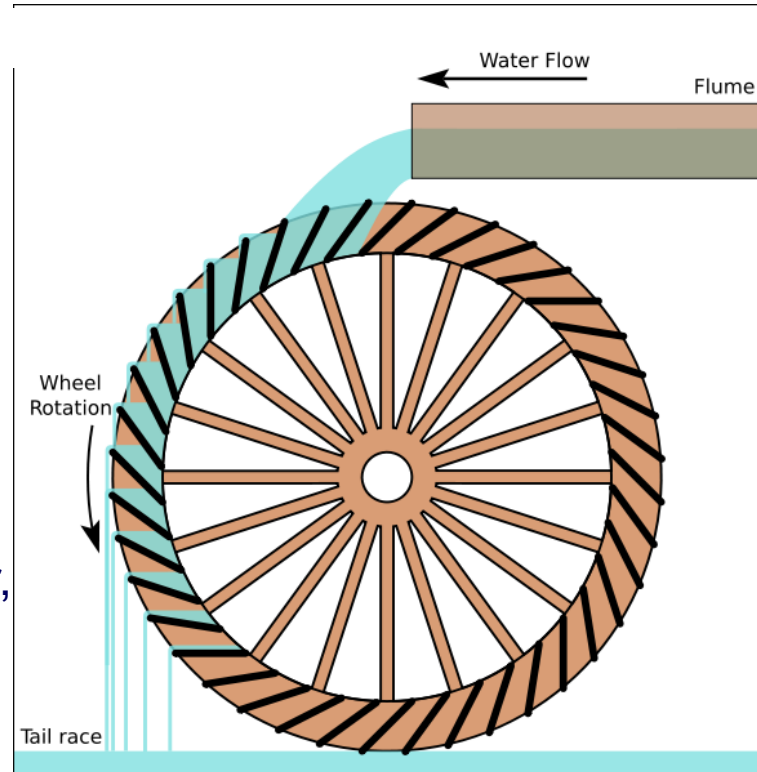

What is the unit of Power?

Power

Since we started with the same definition of power that was used in Mechanics, and derived the power expression for circuits:

$$P = \frac{W}{t} \qquad P = IV$$

Where work is measured in Joules (J) and time is measured in seconds (s) the unit of power is Joules per second (J/s).

In honor of James Watt, who made critical contributions in developing efficient steam engines, the unit of power is known as a Watt (W).

We use the same units for electrical power as mechanical power.

Electrical Power

How can we re-write electrical power by using Ohm's Law?

(electrical power)

$$P = IV$$

(Ohm's Law)

$$I = \frac{V}{R}$$

Substitute Ohm's Law into Electrical Power, replacing I

$$P = \frac{VV}{R}$$

$$P = \frac{V^2}{R}$$

Electrical Power

Is there yet another way to rewrite this?

$$I = \frac{V}{R} \text{ can be rewritten as } V = IR$$

(electrical power)

$$P = IV$$

(Ohm's Law)

$$V = IR$$

Substitute this form of Ohm's Law into electrical power, replacing V

$$P = I(IR)$$

$$P = I^2 R$$

7 A toy car's electric motor has a resistance of 17Ω ; find the power delivered to it by a 6-V battery.

A 0.8 W

B 1.3 W

C 1.6 W

D 2.1 W

E I need help

8 What is the power consumption of a flash light bulb that draws a current of 0.28 A when connected to a 6 V battery?

1.3 W

1.7 W

2.2 W

3.1 W

I need help

9 A 30Ω toaster consumes 560 W of power: how much current is flowing through the toaster?

2.2 A

3.8 A

4.3 A

5.0 A

I need help

10 When 30 V is applied across a resistor it generates 600 W of heat: what is the magnitude of its resistance?

0.7 Ω

1.5 Ω

5.0 Ω

7.2 Ω

I need help

Resistivity and Resistance

[Return to
Table of
Contents](#)

"Pipe" size

How could the wire in the circuit affect the current?

If wire is like a pipe, and current is like water that flows through the pipe...

if there were pipes with water in them, what could we do to the pipes to change the speed of the water (the current)?

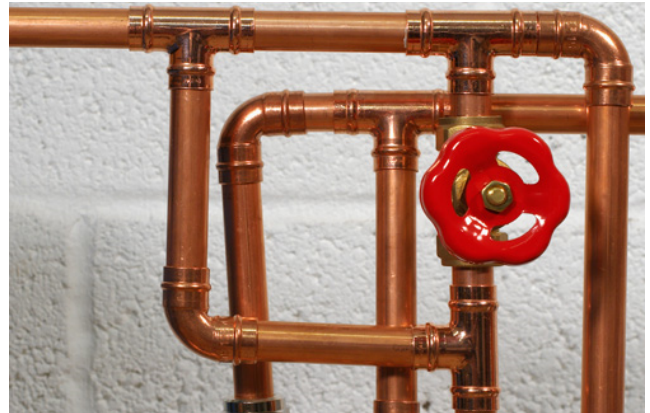

"Pipe" size

Change the cross-sectional area of the pipe.

making it bigger will allow more water to flow

Change the length of the pipe.

increasing the length will increase the time it takes for the water to get to the end of its trip



Resistivity & Resistance

Every conductor "conducts" electric charge to a greater or lesser extent.

The last example also applies to conductors like copper wire. Decreasing the length (L) or increasing the cross-sectional area (A) would increase **conductivity**.

The inverse of conductivity is called **resistivity**. Each material has a different resistivity.

Resistivity is abbreviated using the Greek letter rho (ρ).

Combining what we know about A, L, and ρ , we can find a conductor's total resistance.

$$R = \frac{\rho L}{A}$$

Resistivity & Resistance

$$R = \frac{\rho L}{A}$$

Resistance, R , is measured in Ohms (Ω). Ω is the Greek letter Omega.

Cross-sectional area, A , is measured in m^2

Length, L , is measured in m

Resistivity, ρ , is measured in Ωm

Materials with a low resistivity are preferred for making conducting wires in circuits.

Resistance

What is the resistance of a good conductor?

Low; low resistance means that electric charges are free to move in a conductor.

[Click here for a PhET simulation about Resistance](#)



Resistivities of Common Conductors

Material	Resistivity ($10^{-8} \Omega\text{m}$)
Silver	1.59
Copper	1.68
Gold	2.44
Aluminum	2.65
Tungsten	5.60
Iron	9.71
Platinum	10.6
Mercury	98
Nichrome	100

11 Which of the following groups of materials are listed in order of best conductor to worst conductor? **Select two answers.**

Material	Resistivity ($10^{-8} \Omega\text{m}$)
Silver	1.59
Copper	1.68
Gold	2.44
Aluminum	2.65
Tungsten	5.60
Iron	9.71
Platinum	10.6
Mercury	98
Nichrome	100

- Iron, Copper, Silver
- Iron, Platinum, Mercury
- Platinum, Gold, Copper
- Aluminum, Tungsten, Nichrome
- E I need help

12 What is the resistance of a 2 m long copper wire with a cross-sectional area of 0.2 mm²?

$$\rho_{Cu} = 1.68 \times 10^{-8} \Omega m$$

- A 0.08 Ω
- B 0.12 Ω
- C 0.17 Ω
- D 0.27 Ω
- E I need help

13 The following resistors are made of the same material. Rank them from greatest resistance to least resistance.

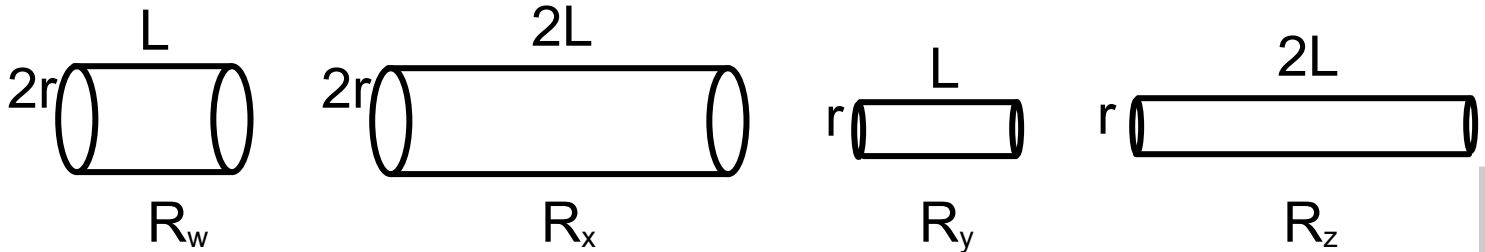

- A $R_x > R_w > R_z > R_y$
- B $R_z > R_y > R_x > R_w$
- C $R_y > R_z > R_w > R_x$
- D $R_y > R_w > R_z > R_x$
- E I need help

$$R = \frac{\rho L}{A}$$

14 What diameter of 100 m long copper wire would have a resistance of 0.10Ω ?

$$\rho_{Cu} = 1.68 \times 10^{-8} \Omega m$$

- 2.2 mm
- 3.7 mm
- 4.6 mm
- 5.4 mm
- I need help

15 The length of a copper wire is cut in half. By what factor does the resistance change ?

- A $1/4$
- B $1/2$
- C 2
- D 4
- E I need help

16 The radius of a copper wire is doubled. By what factor does the resistivity change ?

- A 1/4
- B 1/2
- C 1
- D 2
- E I need help

Circuit Diagrams

[Return to
Table of
Contents](#)

Circuit Diagrams

Drawing realistic pictures of circuits can be very difficult. For this reason, we have common symbols to represent each piece.



Resistor

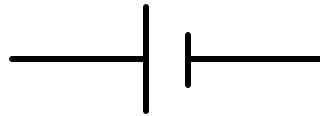

Battery



Wire

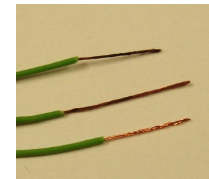

Circuit diagrams do not show where each part is physically located.

Circuit Diagrams

Draw a simple circuit that has a 9 V battery with a 3 Ω resistor across its terminals. What is the magnitude and direction of the current?

Answer

Conventional current flows from the positive terminal to the negative terminal.

Circuit Diagrams

There are two ways to add a second resistor to the circuit.

Series

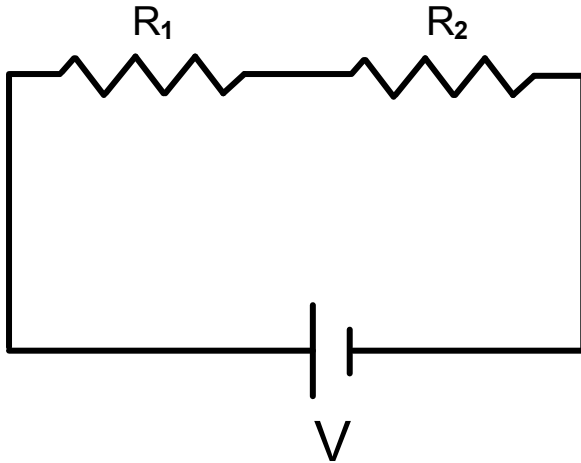

All charges must move through both resistors to get to the negative terminal.

Parallel

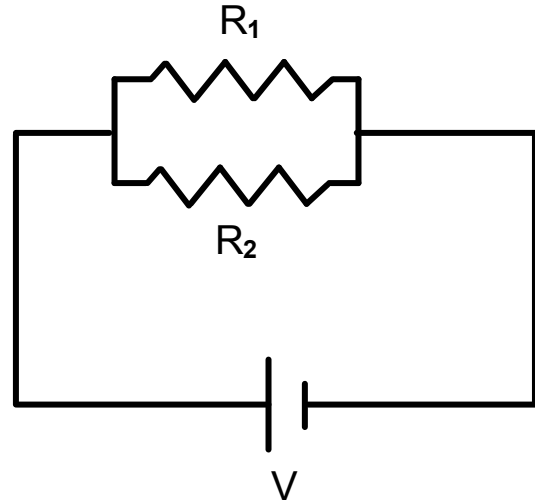

Charges pass through either R_1 or R_2 but not both.

Circuit Diagrams

Are the following sets of resistors in series or parallel?

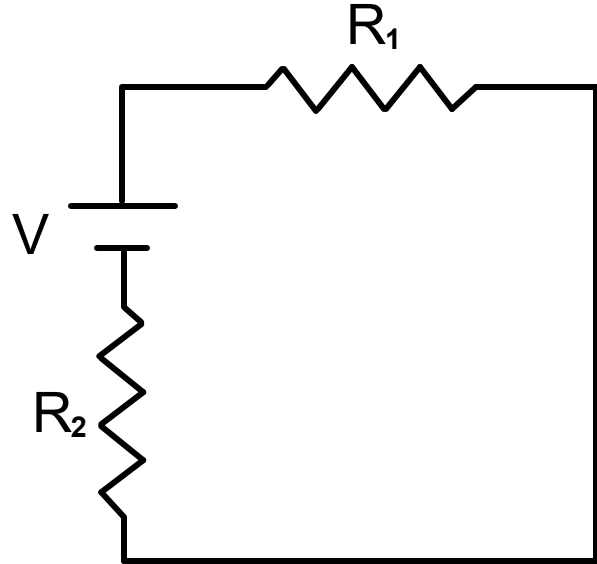
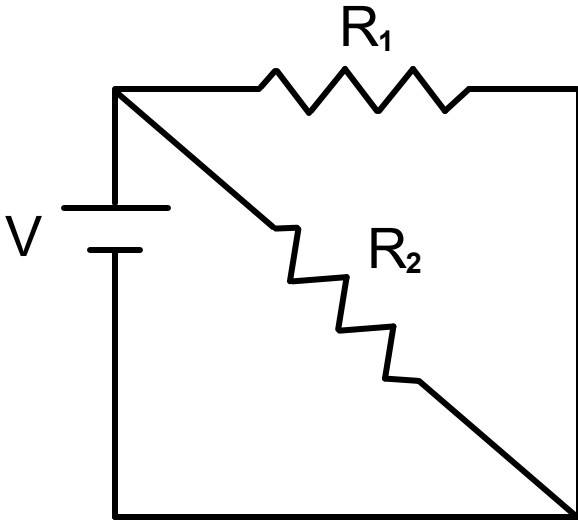

Answer

Equivalent Resistance

Resistors and voltage from batteries determine the current.

Circuits can be redrawn as if there were only a single resistor and battery. By reducing the circuit this way, the circuit becomes easier to study.

The process of reducing the resistors in a circuit is called finding the **equivalent resistance (R_{eq})**.

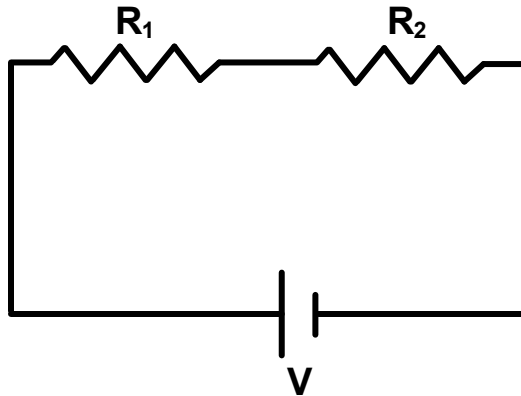

Series Circuits: Equivalent Resistance

What happens to the current in the circuit to the right?

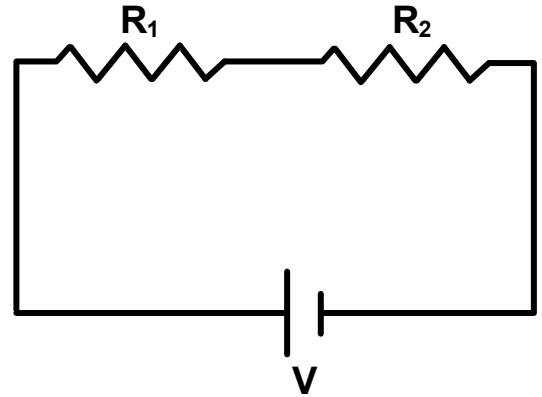

Series Circuits: Equivalent Resistance

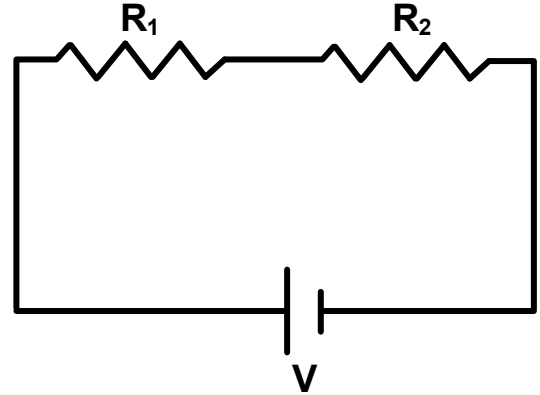

The current passing through all parts of a series circuit is the same. For example: $I = I_1 = I_2$

Series Circuits: Equivalent Resistance

What happens to the voltage as it moves around the circuit?

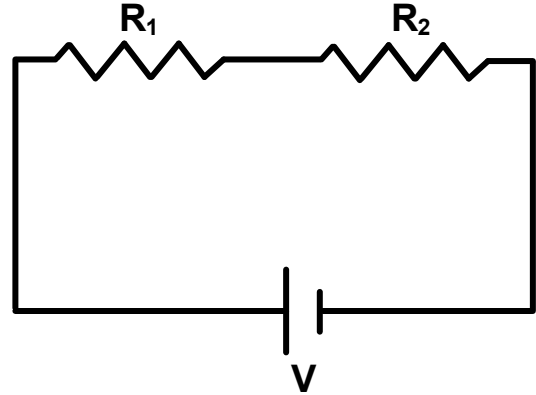

Series Circuits: Equivalent Resistance

The sum of the voltage drops across each of the resistors in a series circuit equals the voltage of the battery.

For example: $V = V_1 + V_2$

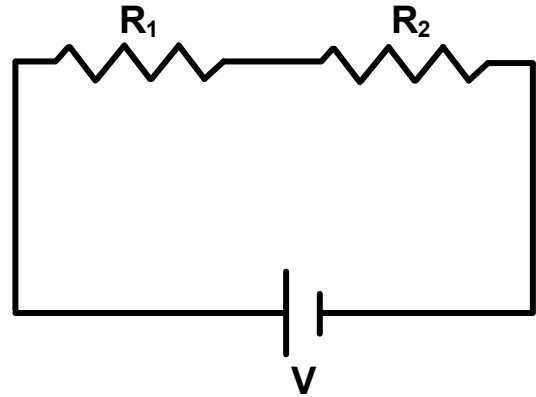

Series Circuits: Equivalent Resistance

$$\text{If } V = V_1 + V_2 + V_3 + \dots$$

substitute Ohm's Law solved for V is: $V = IR$

$$IR = I_1R_1 + I_2R_2 + I_3R_3$$

but since current (I) is the same everywhere in a series circuit,

$$IR = IR_1 + IR_2 + IR_3$$

$$I = I_1 = I_2 = I_3$$

$$R_{\text{eq}} = R_1 + R_2 + R_3 + \dots$$

Now divide by I

To find the equivalent resistance (R_{eq}) of a series circuit, add the resistance of all the resistors. If you add more resistors to a series circuit, what happens to the resistance?

17 What is the equivalent resistance in this circuit?

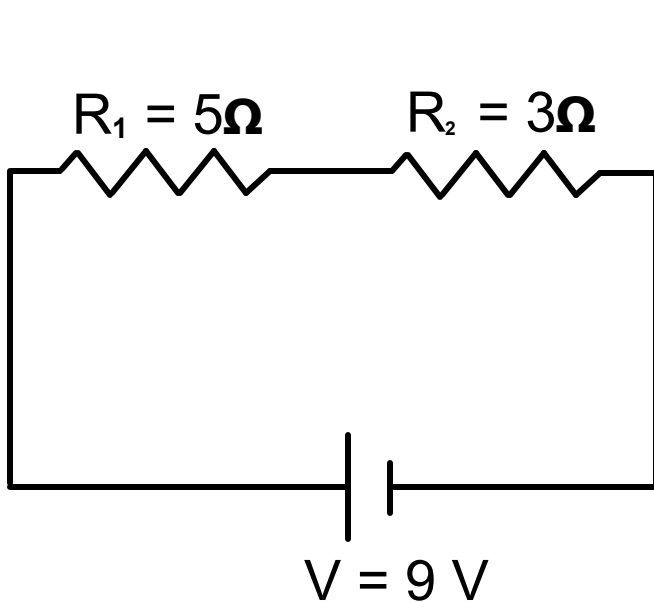

- A $3\ \Omega$
- B $5\ \Omega$
- C $8\ \Omega$
- D $9\ \Omega$
- E I need help

18 What is the total current at any spot in the circuit?

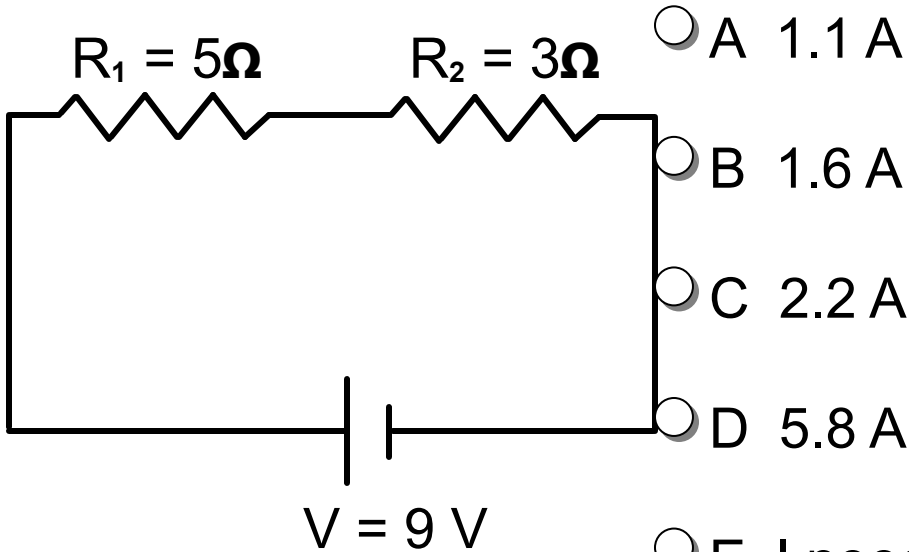

- A 1.1 A
- B 1.6 A
- C 2.2 A
- D 5.8 A
- E I need help

19 What is the voltage drop across R_1 ?

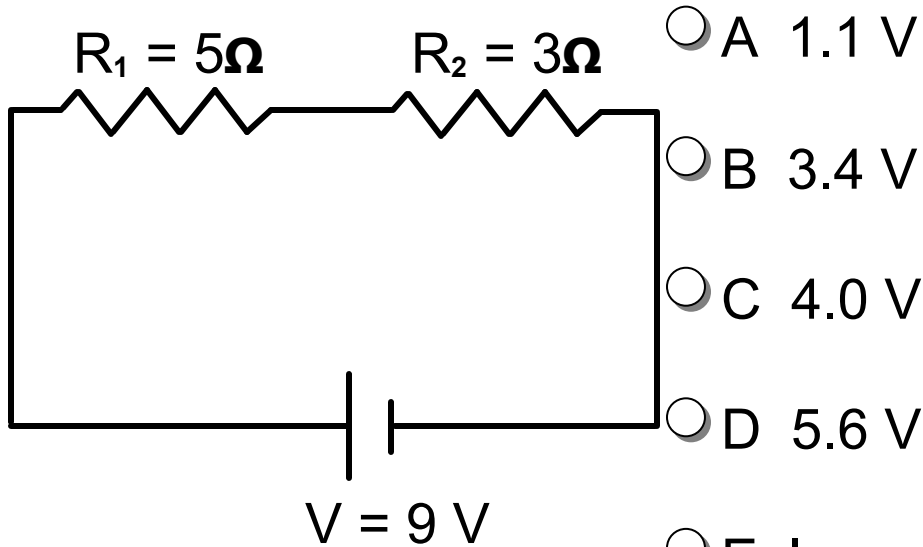

- A 1.1 V
- B 3.4 V
- C 4.0 V
- D 5.6 V
- E I need help

20 What is the voltage drop across R_2 ?

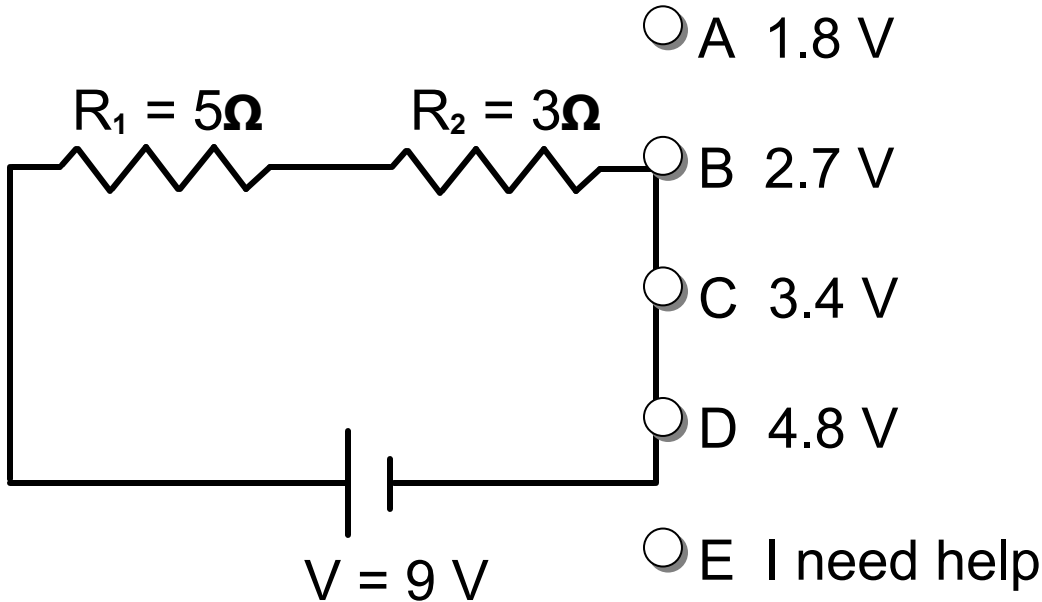

hint: A good way to check your work is to see if the voltage drop across all resistors equals the total voltage in the circuit.

21 How much power is used by R_1 ?

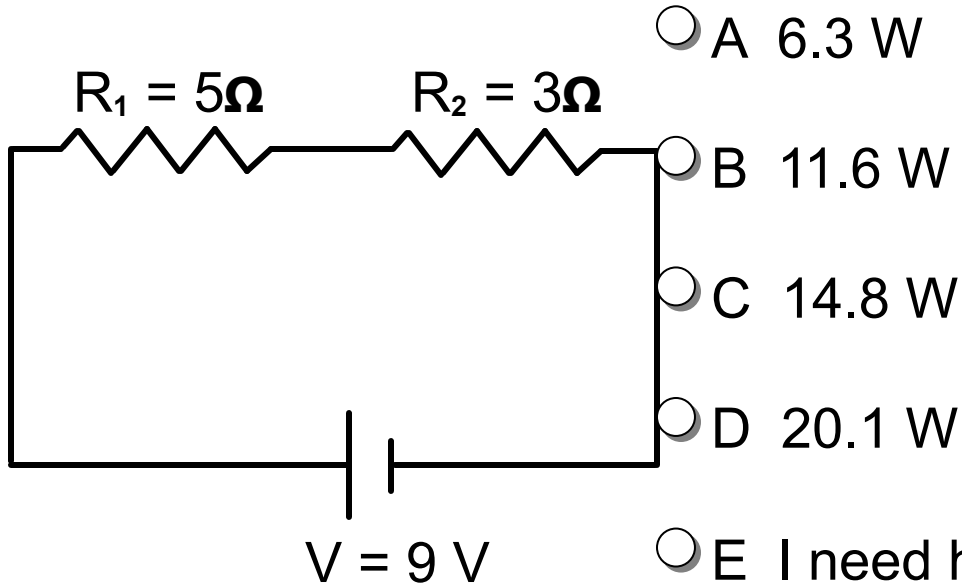

- A 6.3 W
- B 11.6 W
- C 14.8 W
- D 20.1 W
- E I need help

Parallel Circuits: Equivalent Resistance

What happens to the current in the circuit to the right?

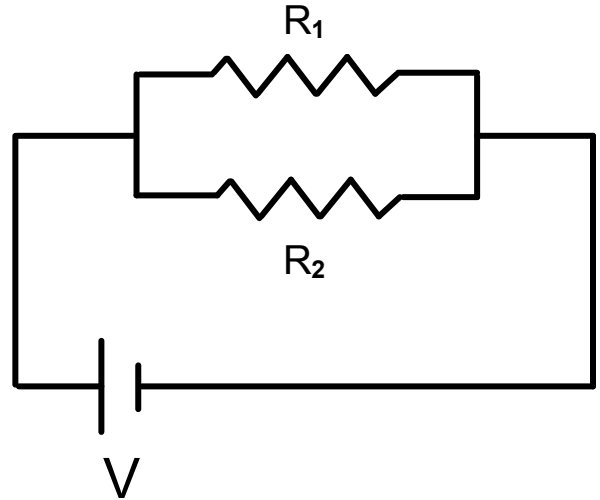

Parallel Circuits: Equivalent Resistance

The sum of the currents through each of the resistors in a parallel circuit equals the current of the battery.

For example: $I = I_1 + I_2$

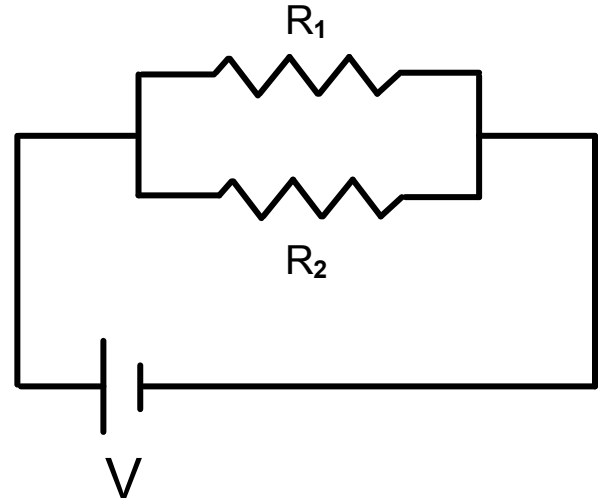

Parallel Circuits: Equivalent Resistance

What happens to the voltage as it moves around the circuit?

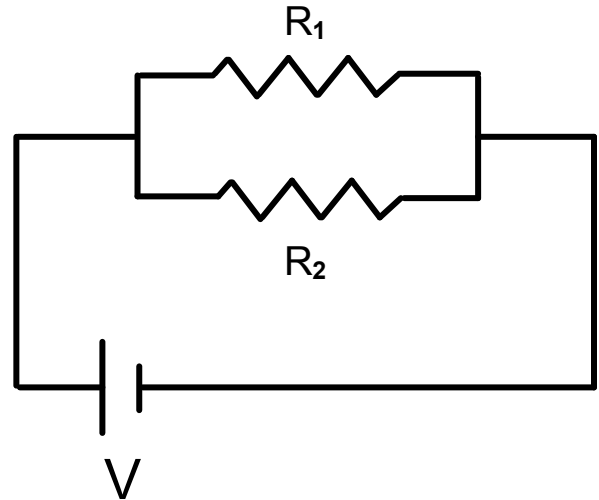

Parallel Circuits: Equivalent Resistance

The voltage across all the resistors in a parallel circuit is the same.

For example: $V = V_1 = V_2$

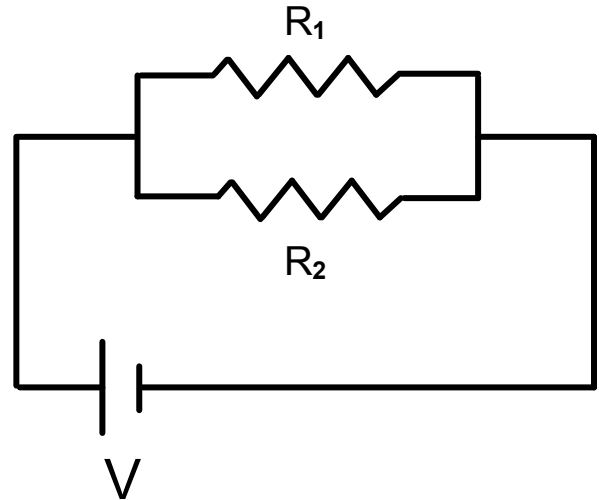

Parallel Circuits: Equivalent Resistance

$$\text{If } I = I_1 + I_2 + I_3$$

Rewrite Ohm's Law for I and substitute for each resistor

$$\frac{V}{R} = \frac{V_1}{R_1} + \frac{V_2}{R_2} + \frac{V_3}{R_3}$$

Also, since $V = V_1 = V_2 = V_3$, we can substitute V for any other voltage

$$\frac{V}{R} = \frac{V}{R_1} + \frac{V}{R_2} + \frac{V}{R_3}$$

Voltage is a common factor, so factor it out!

$$\frac{V}{R} = V \left(\frac{1}{R_1} + \frac{1}{R_2} + \frac{1}{R_3} \right)$$

Divide by V to eliminate voltage from the equation.

$$\frac{1}{R_{\text{eq}}} = \frac{1}{R_1} + \frac{1}{R_2} + \frac{1}{R_3}$$

If you add more resistors in parallel, what will happen to the resistance of the circuit?

Parallel Circuits: Equivalent Resistance

$$\frac{1}{R_{\text{eq}}} = \frac{1}{R_1} + \frac{1}{R_2} + \frac{1}{R_3}$$

Adding more resistors will decrease the equivalent resistance of the parallel circuit. Check the math out and you'll see that's true.

Conceptually, adding more resistors in parallel gives more paths for the electrons to flow - hence, for a given electric potential, more current will flow which indicates a smaller resistance.

22 What is the equivalent resistance in the circuit?

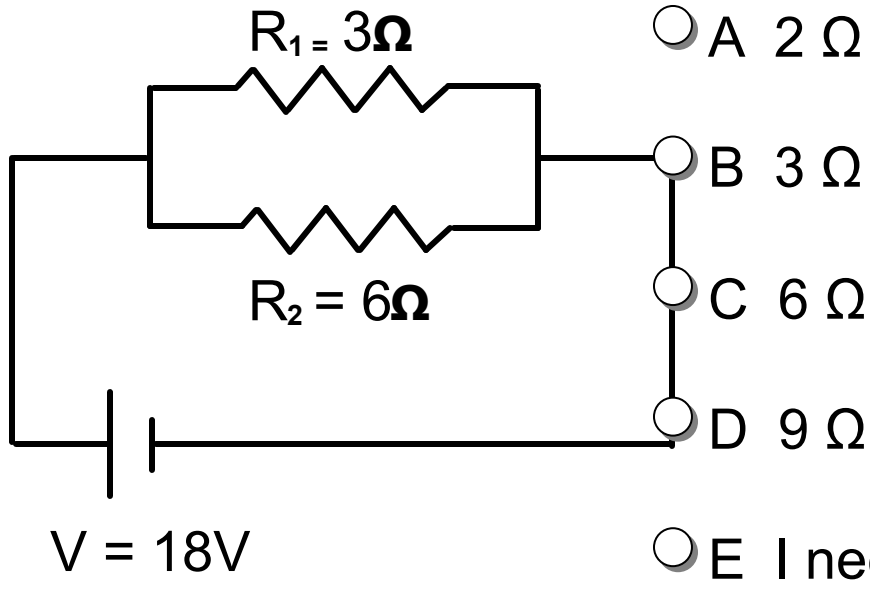

A 2Ω

B 3Ω

C 6Ω

D 9Ω

E I need help

Answer

23 What is the voltage drop across R_1 ?

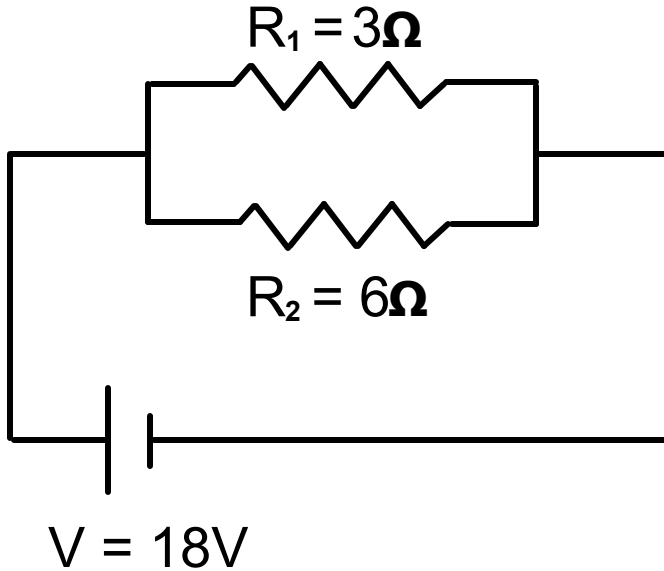

- 3 V
- 6 V
- 9 V
- 18 V
- I need help

24 What is the current through R_1 ?

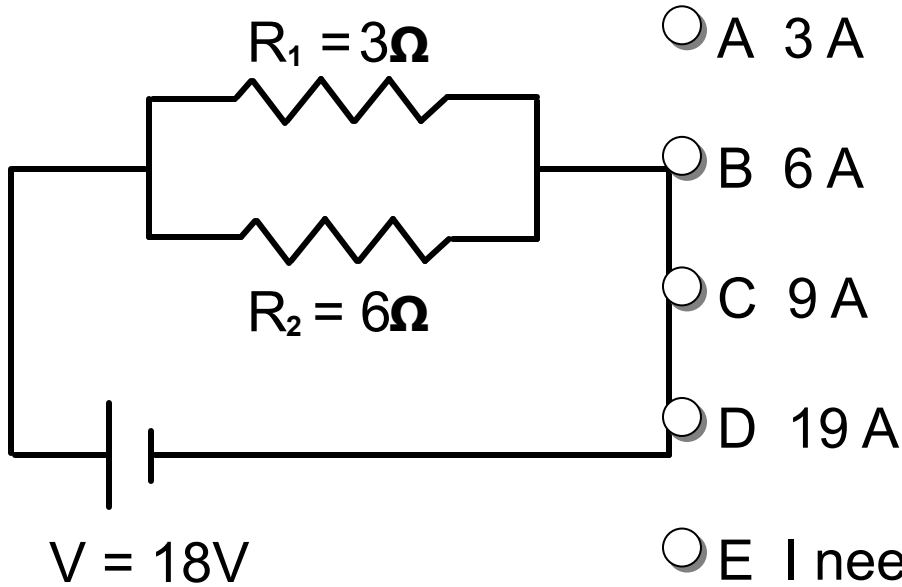

Answer

25 What is the current through R_2 ?

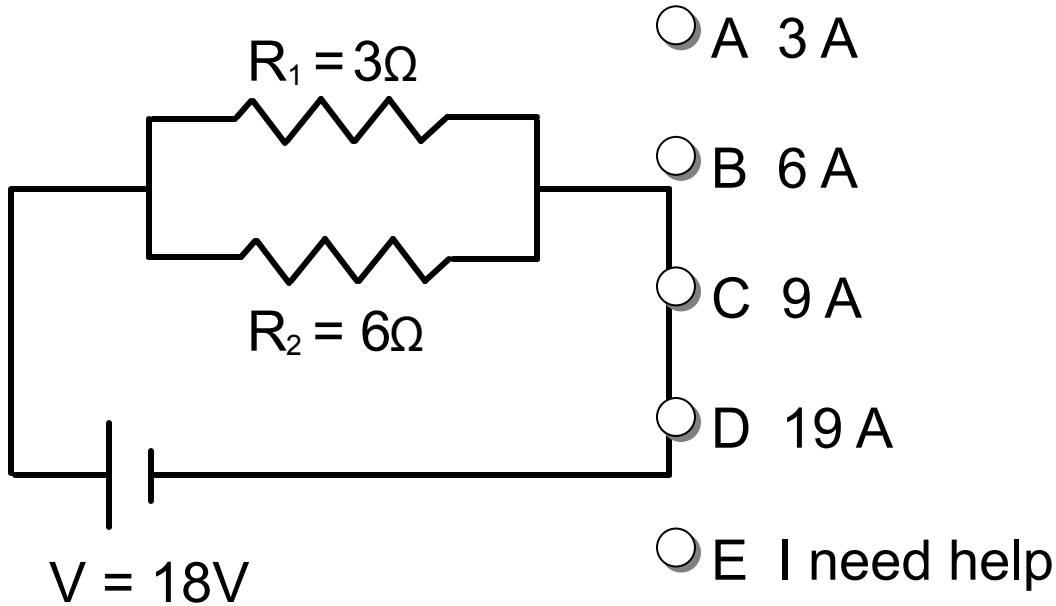

26 What is the power used by R_1 ?

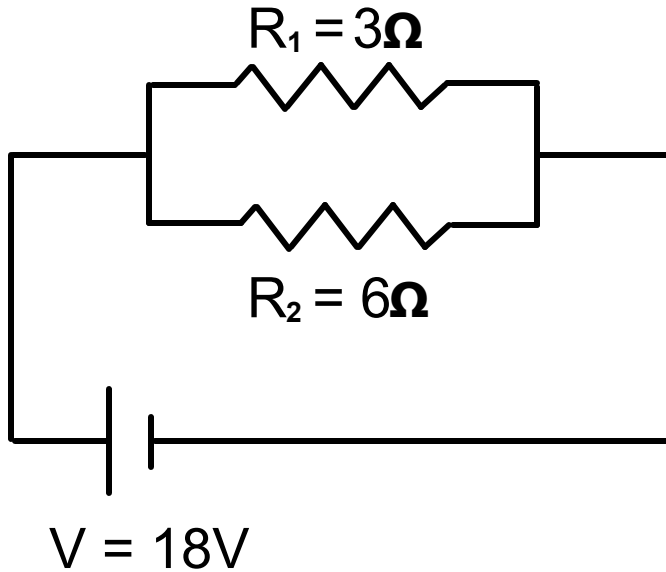

- 56 W
- 66 W
- 80 W
- 108 W
- I need help

27 What is the power used by R_2 ?

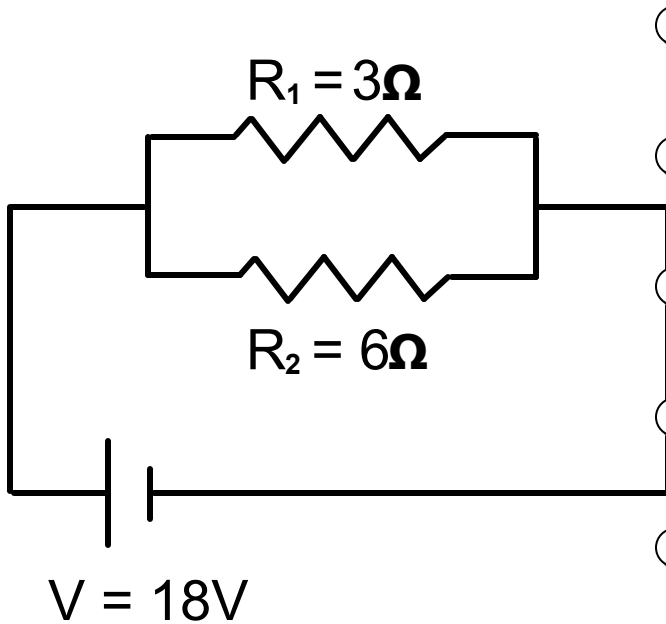

- A 11 W
- B 28 W
- C 48 W
- D 54 W
- E I need help

28 What is the total current in this circuit ?

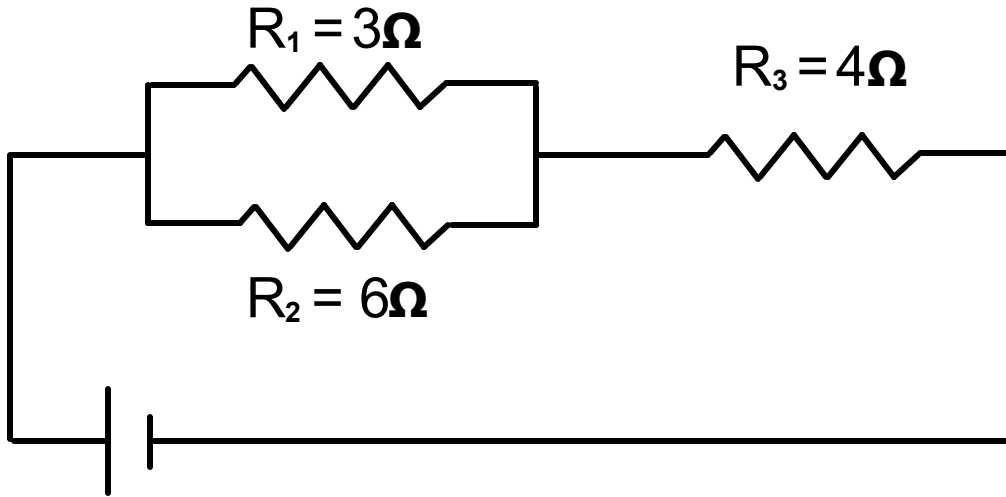

$V = 18V$

- A 1 A
- B 3 A
- C 6 A
- D 9 A
- I need help

29 What is the voltage drop across R_3 ?

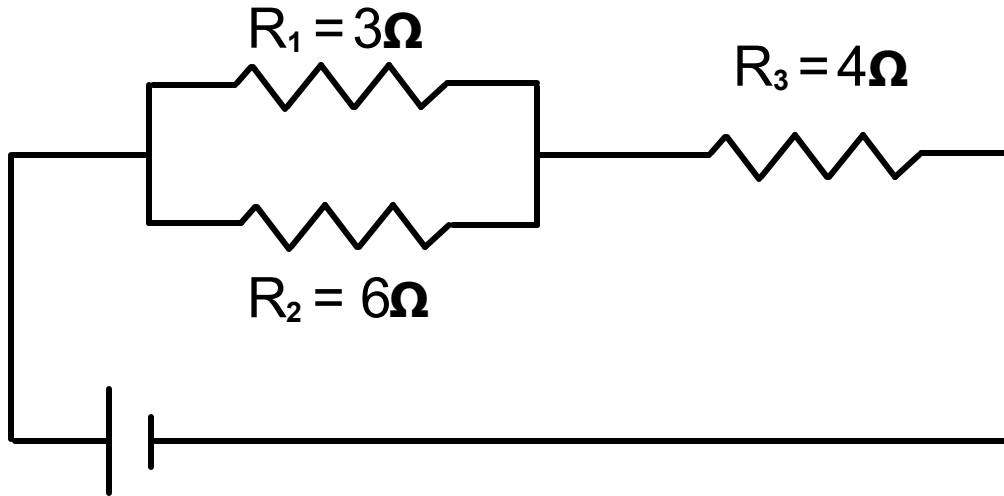

$V = 18V$

- A 3 V
- B 4 V
- C 12 V
- D 16 V
- E I need help

30 What is the current through R_1 ?

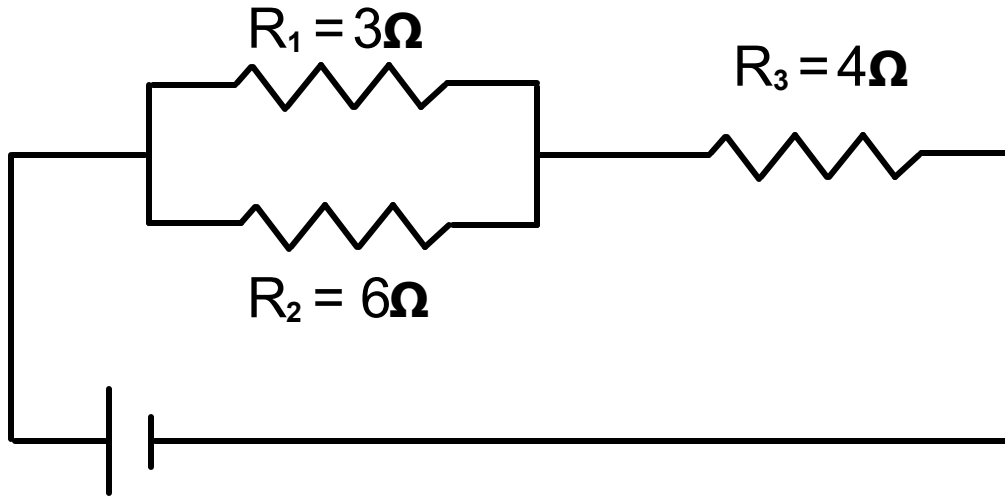

$V = 18\text{V}$

- A 1 A
- B 2 A
- C 4 A
- D 6 A
- E I need help

1

Answer

2

Answer

31 Which two of the following sets of resistors have the same equivalent resistance? **Select two answers.**

A

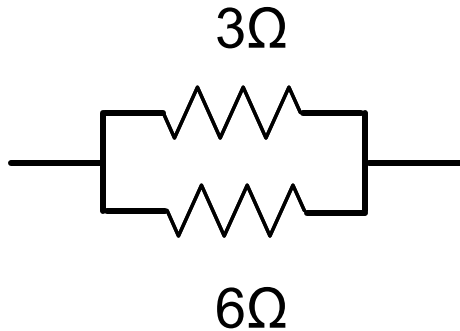

B

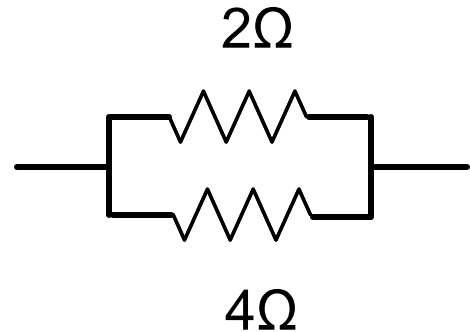

C



D



I need help

Measurement

[Return to
Table of
Contents](#)

Voltmeter

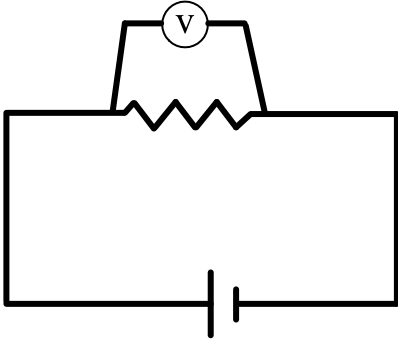

Voltage is measured with a voltmeter. Voltmeters are connected in parallel and measure the difference in potential between two points.

Since circuits in parallel have the same voltage, and a voltmeter has very high resistance, very little current passes through it.

This means that it has little effect on the circuit.

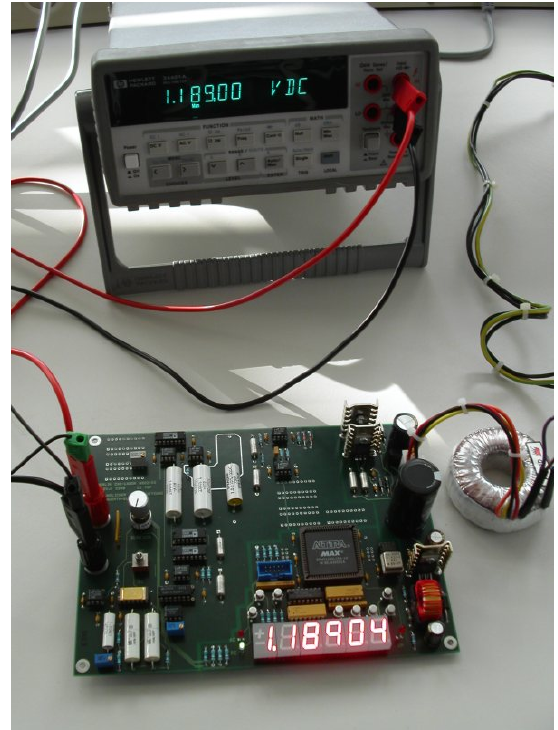

Ammeter

Current is measured using an ammeter.



Ammeters are placed in series with a circuit. In order to not interfere with the current, the ammeter has a very low resistance.

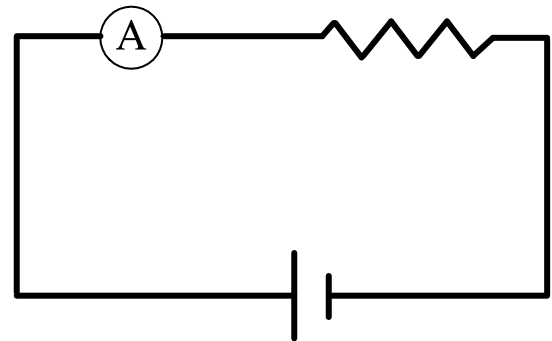

Multimeter

Although there are separate items to measure current and voltage, there are devices that can measure both (one at a time).

These devices are called multimeters. Multimeters can also measure resistance.

[Click here for a PhET simulation on circuits](#)



32 A group of students prepare an experiment with electric circuits. Which of the following diagrams can be used to measure both current and voltage in the light bulb, L?

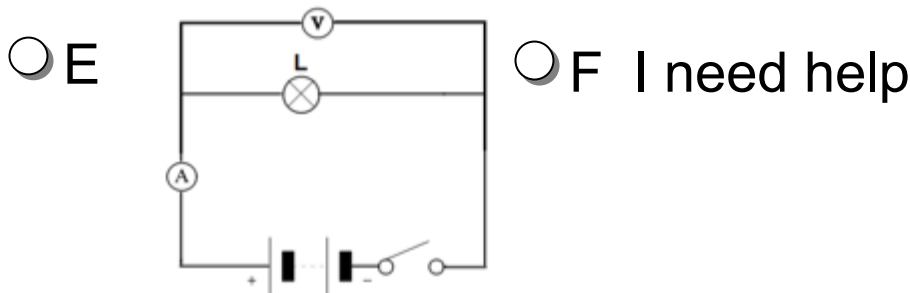
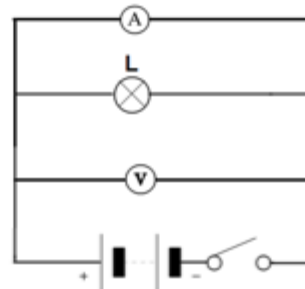
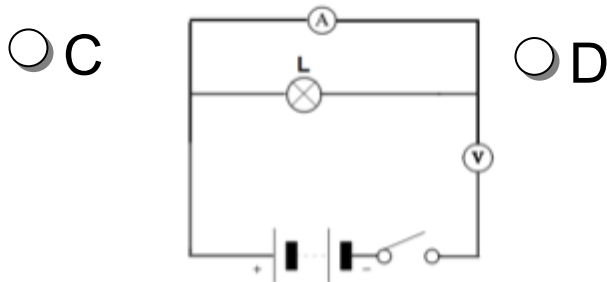
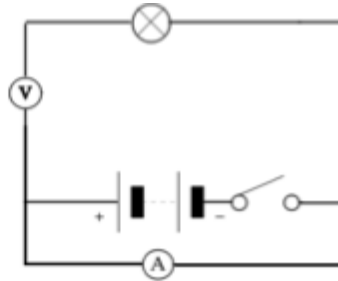
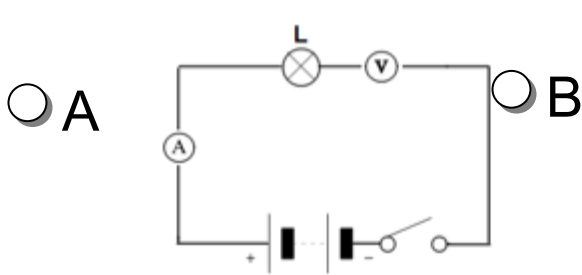

EMF & Terminal Voltage

[Return to Table of Contents](#)

Electromotive Force

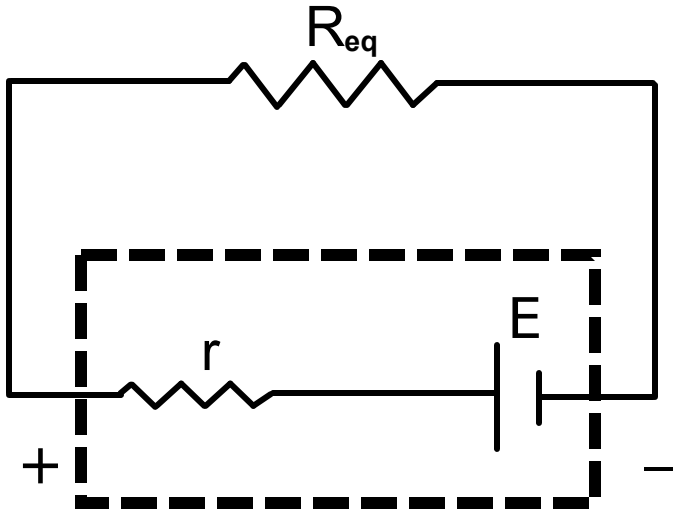

A battery is a source of voltage AND a resistor.

Each battery has a source of electromotive force and internal resistance.

Electromotive force (EMF) is the process that carries charge from low to high voltage.

Another way to think about it is that EMF is the voltage you measure when no resistance is connected to the circuit.

Electromotive Force

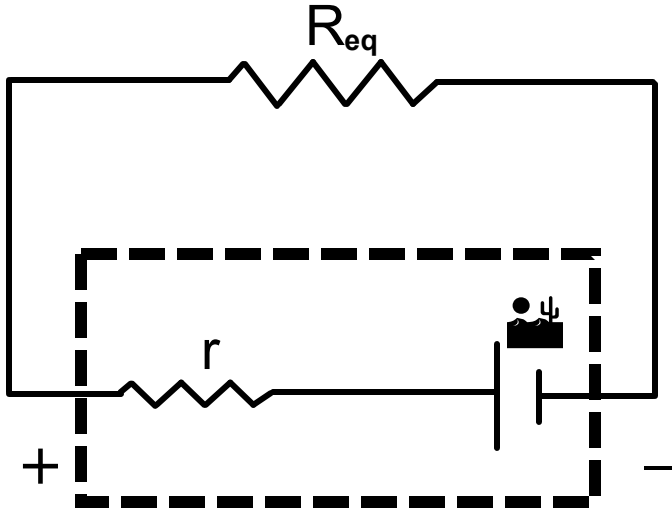

Terminal voltage (V_T) is the voltage measured when a voltmeter is across its terminals.

If there is no circuit attached, no current flows, and the measurement will equal the EMF.

If however a circuit is attached, the internal resistance will result in a voltage drop, and a smaller terminal voltage. ($\epsilon - Ir$)

Terminal Voltage

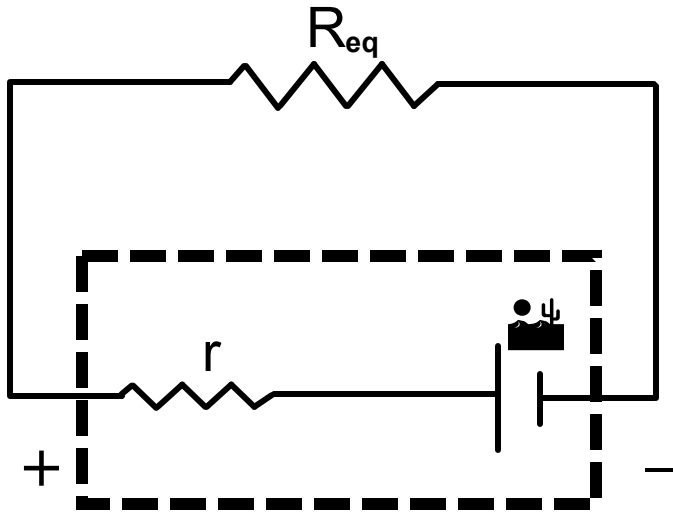

We say that the terminal voltage is:

$$V_T = \varepsilon - Ir$$

Terminal voltage is a maximum when there is no current flowing.

When solving for equivalent resistance in a circuit, the internal resistance of the battery is considered a series resistor.

$$R_{EQ} = R_{int} + R_{ext}$$

33 When the switch in the below circuit is open, the voltmeter reading is referred to as:

- A EMF
- B Current
- C Power
- D Terminal Voltage
- I need help

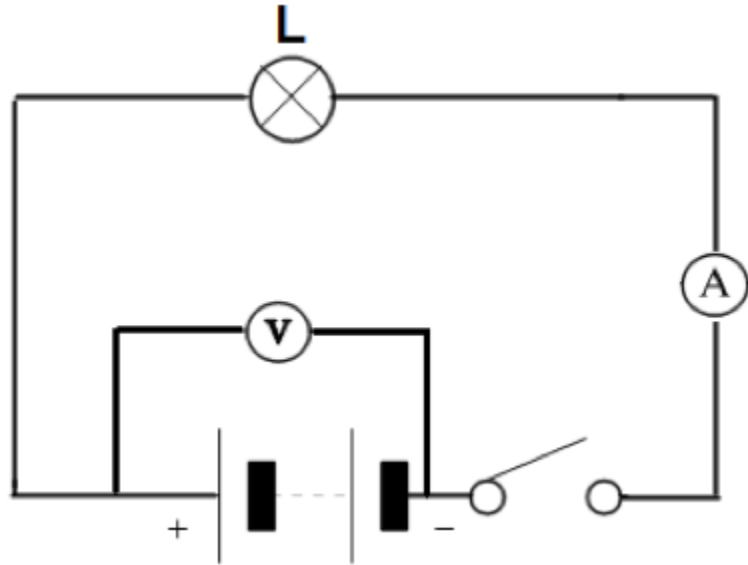

Answer

34 When the switch in the below circuit is closed, the voltmeter reading is referred to as:

- A EMF
- B Current
- C Power
- D Terminal Voltage
- I need help

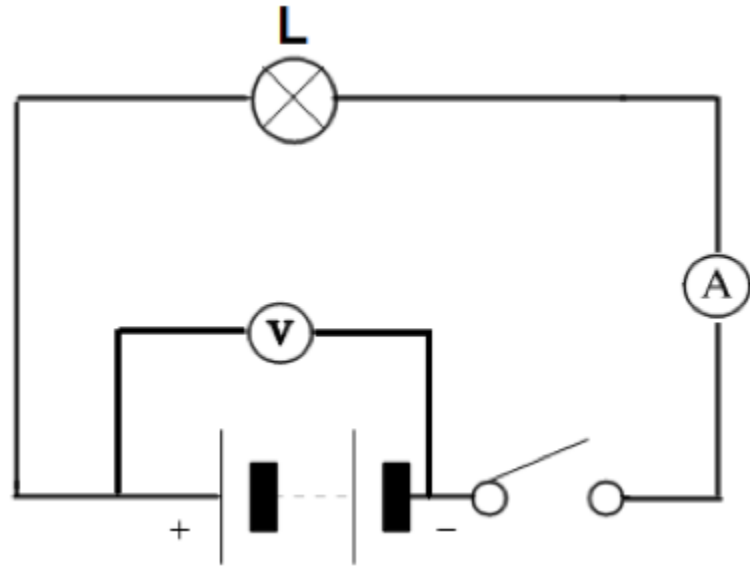

35 A 6V battery, with an internal resistance of 1.5Ω , is connected in series to a light bulb with a resistance of 6.8Ω . What is the current in the circuit?

- A 0.14 A
- B 0.46 A
- C 0.65 A
- D 0.72 A
- E I need help

36 A 6 V battery, whose internal resistance 1.5Ω is connected in series to a light bulb with a resistance of 6.8Ω . What is the terminal voltage of the battery?

1.4 V

2.8 V

3.3 V

4.9 V

I need help

Answer

37 A $25\ \Omega$ resistor is connected across the terminals of a battery whose internal resistance is $0.6\ \Omega$. What is the EMF of the battery if the current in the circuit is $0.75\ \text{A}$?

- A $4.6\ \text{V}$
- B $8.9\ \text{V}$
- C $16.1\ \text{V}$
- D $19.2\ \text{V}$
- E I need help

Kirchhoff's Rules

[Return to
Table of
Contents](#)

Kirchhoff's Rules

Up until this point we have been analyzing simple circuits by combining resistors in series and parallel and using Ohm's law.

This works for simple circuits but in order analyze more complex circuits we need to use Kirchhoff's Rules which are based on the laws of conservation of charge and energy.

Kirchhoff's Rules

Kirchhoff's First rule, or **junction rule** is based on the law of conservation of charge. It states:

At any junction point (marked by a dot), the sum of all currents entering the junction point must equal the sum of all the currents exiting the junction.

For example,

$$I_1 + I_2 = I_3$$

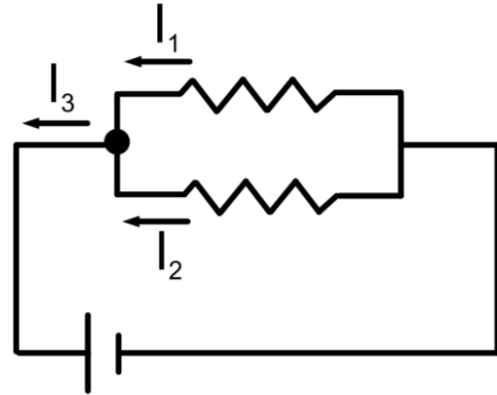

Kirchhoff's Rules

Kirchhoff's Second rule , or **loop rule** is based on the law of conservation of energy. It states:

The sum of all changes in potential around any closed path must equal zero.

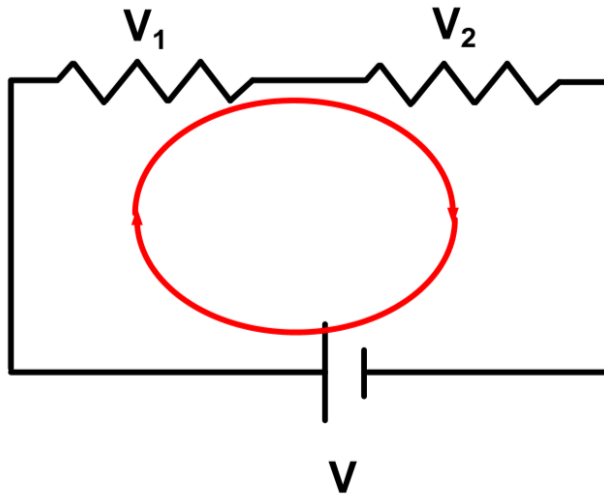

Kirchhoff's Rules

For the clockwise path shown below (in the same direction as the conventional current), Potential is positive leaving the battery, and is negative (drops) across the resistors. If the path were chosen in the

For example,

The sum of the voltage drops is equal to the voltage across the battery.

$$V - V_1 - V_2 = 0 \quad \text{OR} \quad V = V_1 + V_2$$

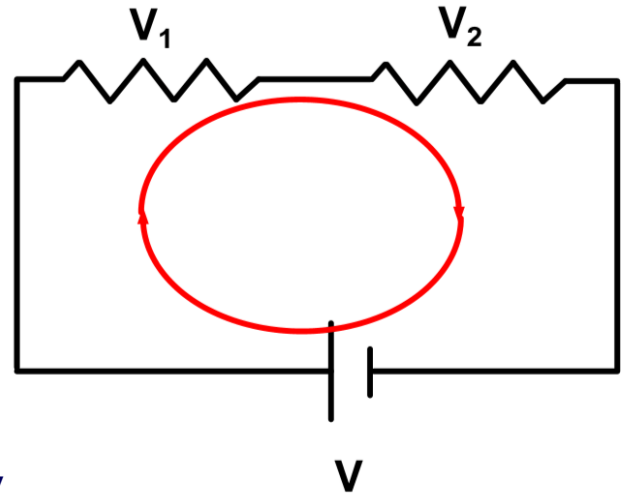

38 Kirchoff's Junction Rule is based on which conservation law?

- A Conservation of Charge
- B Conservation of Energy
- C Conservation of Momentum
- D Conservation of Mass
- I need help

39 Kirchoff's Loop Rule is based on which conservation law?

- A Conservation of Charge
- B Conservation of Energy
- C Conservation of Momentum
- D Conservation of Mass
- I need help

Problem Solving with Kirchhoff's Rules

1. Draw an expected direction of the current for each circuit element. The direction doesn't matter; if it turns out the real direction is in the opposite direction, you'll get a negative value for the current.
2. Label each resistor with a (+) and a (-) sign. The (+) sign is where the drawn current enters the resistor.
3. Apply the junction rule to each junction. You need as many equations as there are unknowns. (You can also use Ohm's Law to reduce the number of unknowns.)

Problem Solving with Kirchhoff's Rules

4. Apply the loop rule for each loop. Draw a loop and sum up the voltages in the loop to equal zero.

a. If while traversing a loop, you enter the positive side of the resistor, apply a negative sign to the voltage.

b. If you enter the negative side of the resistor, apply a positive sign.

c. The battery V is positive if you leave the positive terminal with the loop.

$$V - V_1 - V_2 = 0$$

$$V - I_1 R_1 - I_2 R_2 = 0$$

5. Solve the equations algebraically.

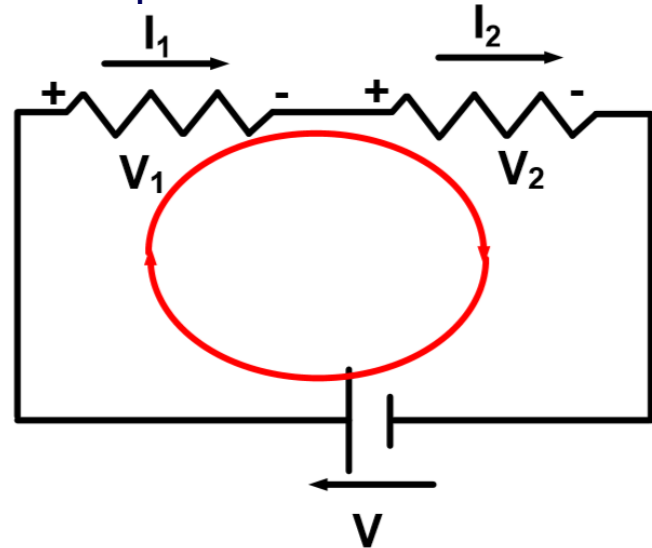

Problem Solving with Kirchhoff's Rules

Find the unknown currents, voltages and resistances in the following circuit:

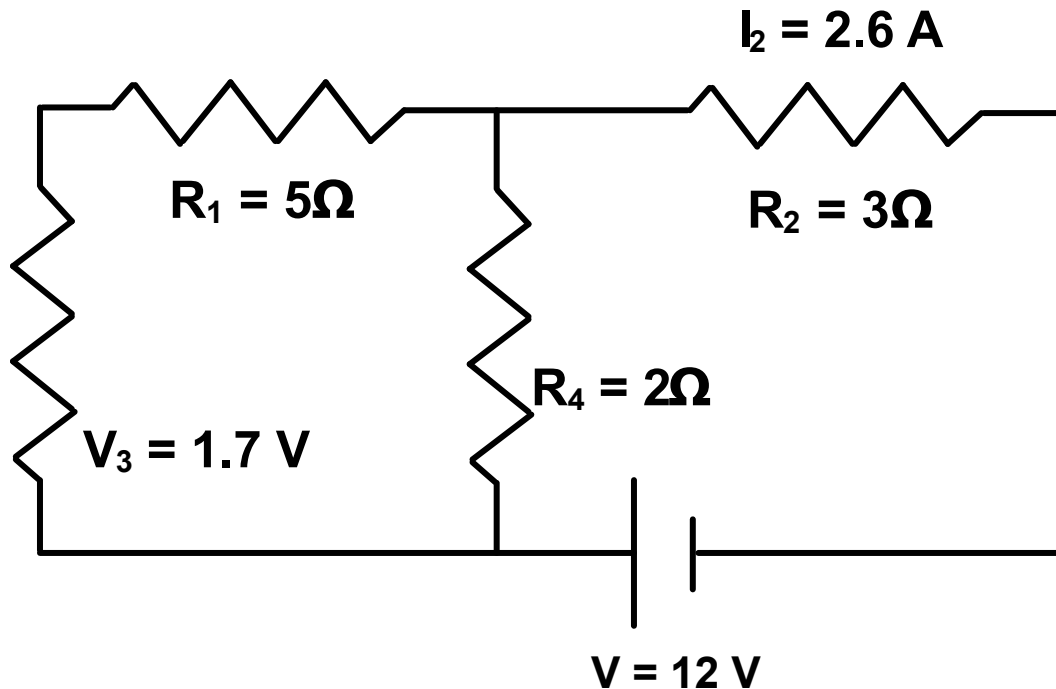

Problem Solving with Kirchhoff's Rules

1. Draw an expected direction of the current for each circuit element. The direction doesn't matter; if it turns out the real direction is in the opposite direction, you'll get a negative value for the current.

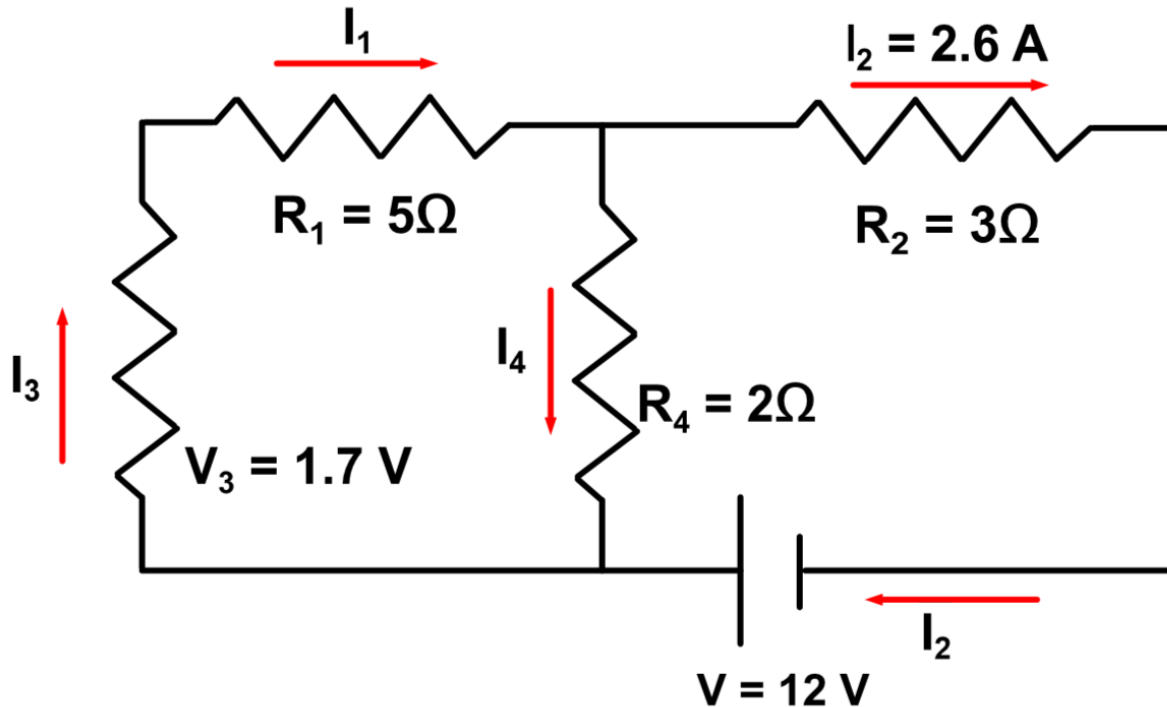

Problem Solving with Kirchhoff's Rules

2. Label each resistor with a (+) and a (-) sign. The (+) sign is where the drawn current enters the resistor.

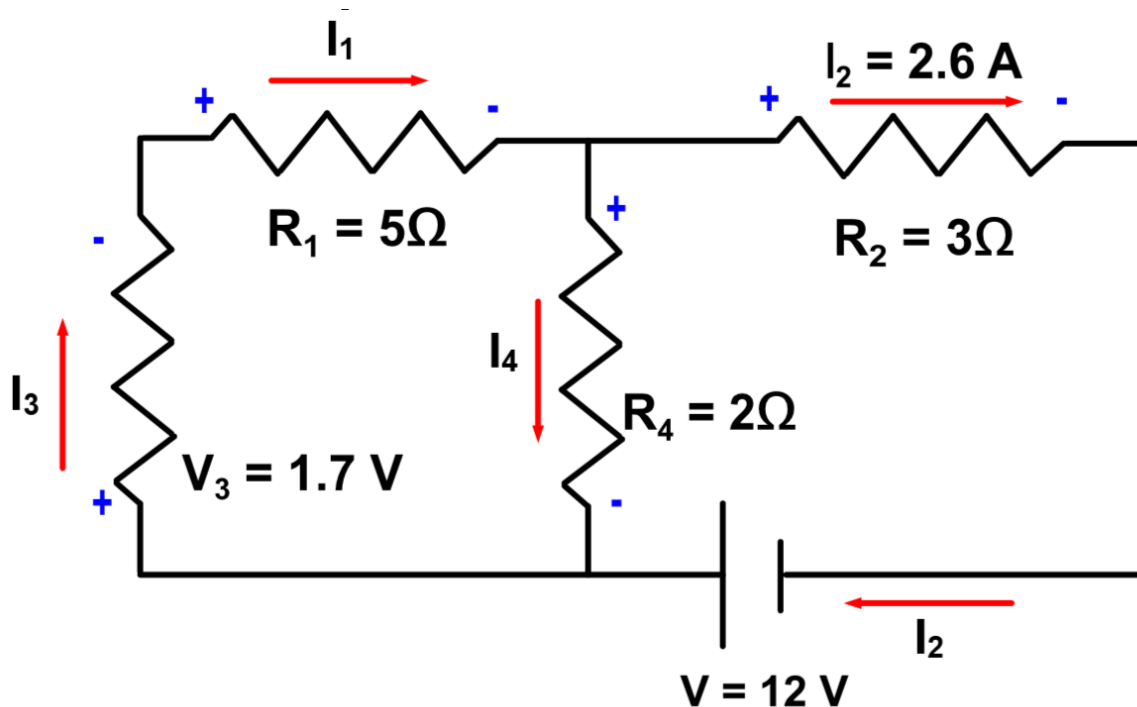

Problem Solving with Kirchhoff's Rules

3. Apply the junction rule to each junction. You need as many equations as there are unknowns. (You can also use Ohm's Law to reduce the number of unknowns.)

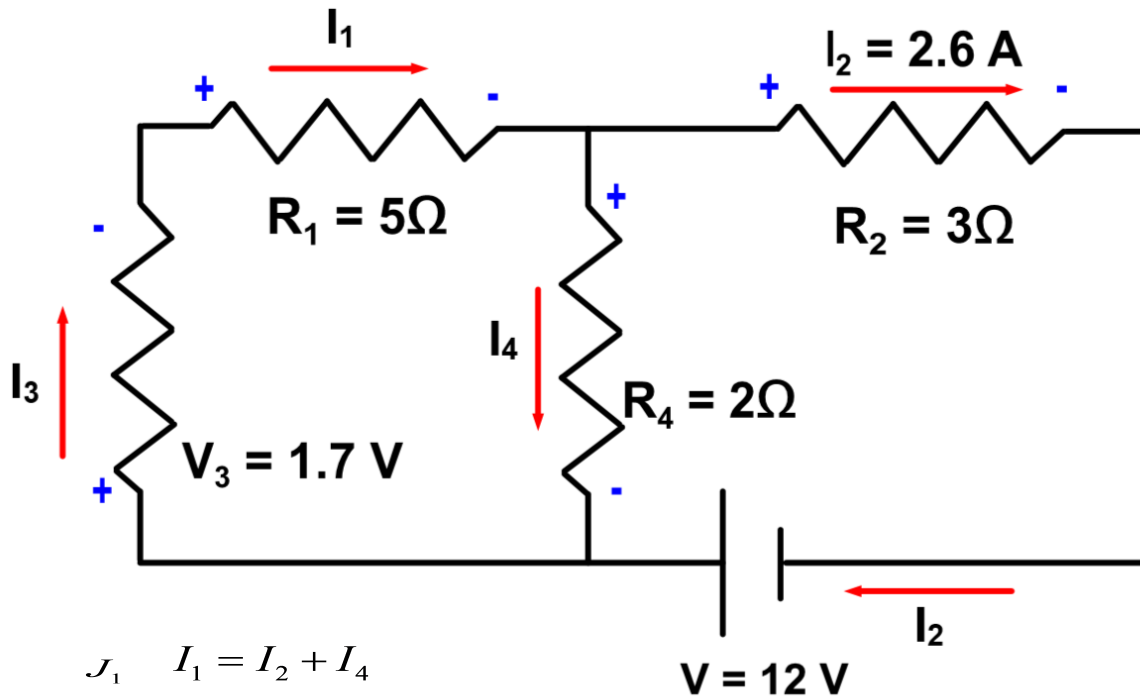

$$J_1 \quad I_1 = I_2 + I_4$$

$$J_2 \quad I_2 + I_4 = I_3$$

Problem Solving with Kirchhoff's Rules

4. Apply the loop rule for each loop. Draw a loop and sum up the voltages in the loop to equal zero.

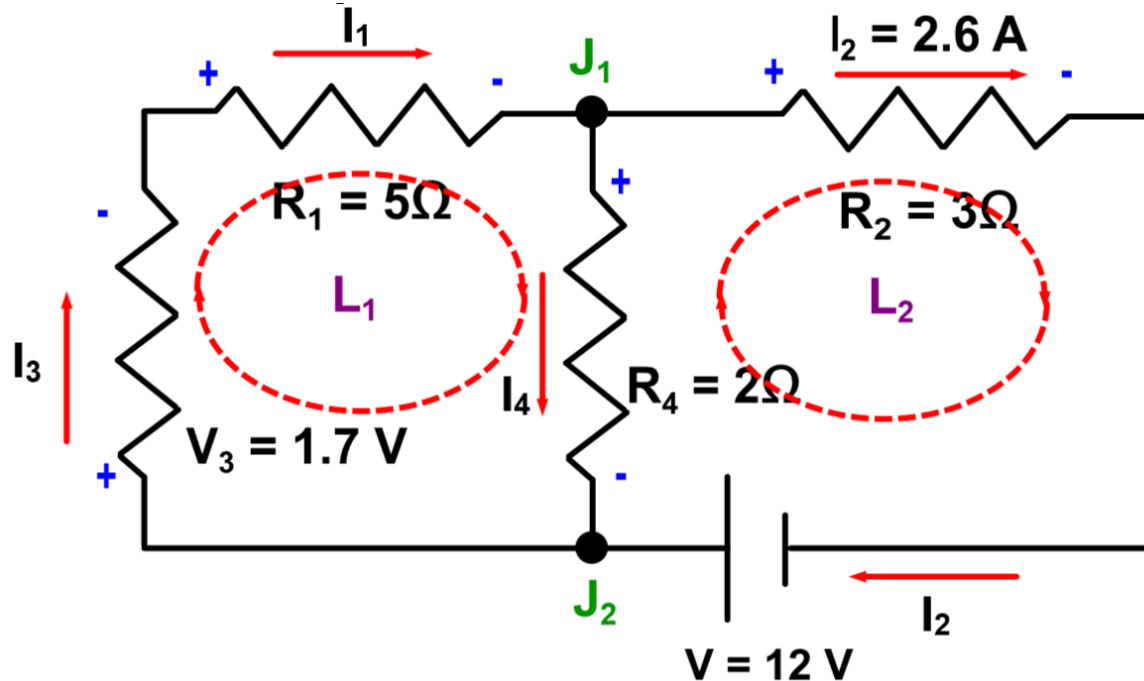

$$L_1 \quad -V_3 - V_1 - V_4 = 0$$

$$-I_3 R_3 - I_1 R_1 - I_4 R_4 = 0$$

$$L_2 \quad V + V_4 - V_2 = 0$$

$$V + I_4 R_4 - I_2 R_2 = 0$$

Problem Solving with Kirchhoff's Rules

5. Solve the equations algebraically - input the given values.

$$\begin{aligned} \mathcal{J}_1 \quad I_1 &= I_2 + I_4 \\ I_1 &= 2.6 + I_4 \end{aligned}$$

$$\begin{aligned} \mathcal{J}_2 \quad I_2 + I_4 &= I_3 \\ 2.6 + I_4 &= I_3 \end{aligned}$$

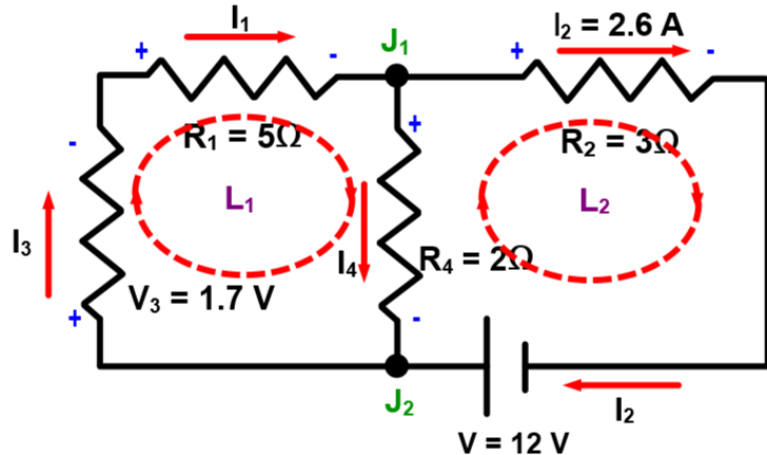

$$\begin{aligned} \mathcal{L}_1 \quad -V_3 - V_1 - V_4 &= 0 \\ -I_3 R_3 - I_1 R_1 - I_4 R_4 &= 0 \\ -1.7 - 5I_1 - 2I_4 &= 0 \end{aligned}$$

$$\begin{aligned} \mathcal{L}_2 \quad V + V_4 - V_2 &= 0 \\ V + I_4 R_4 - I_2 R_2 &= 0 \\ 12 + 2I_4 - 7.8 &= 0 \end{aligned}$$

Since I_2 and R_2 were both given, we find $V_2 = I_2 R_2 = (2.6 \text{ A})(3 \Omega) = 7.8 \text{ V}$.

Problem Solving with Kirchhoff's Rules

Continue the algebra:

$$J_1 \quad I_1 = 2.6 + I_4$$

$$J_2 \quad 2.6 + I_4 = I_3$$

$$L_1 \quad -1.7 - 5I_1 - 2I_4 = 0$$

$$L_2 \quad 12 + 2I_4 - 7.8 = 0$$

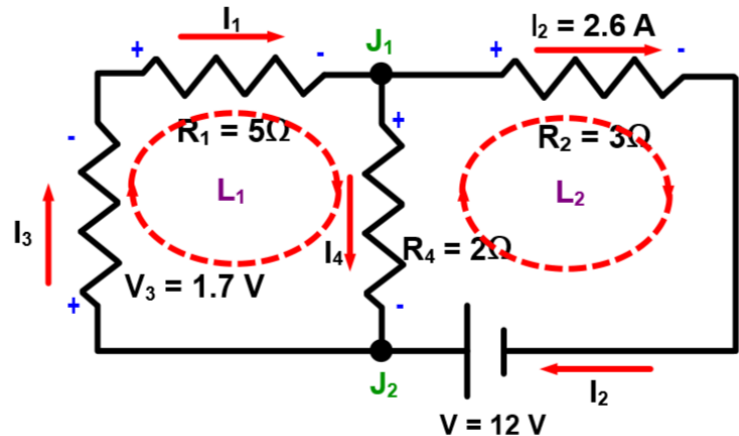

It's a matter of practice and insight now. Look at equation L_2 . We can solve that for I_4 . $I_4 = -2.1A$. No problem, it just tells us that I_4 actually goes up, not down!

Plug that value for I_4 into equation L_1 to find I_1 . $I_1 = 0.5A$.

Use equation J_2 to find I_3 . $I_3 = 0.5A$.

Problem Solving with Kirchhoff's Rules

A table is a great way to keep track of your work. The givens are in red ink. We've now found all the currents, and we found V_2 . Put them in the table (in light blue).

Resistor	Current (A)	Voltage (V)	Resistance (Ω)
R_1	0.5		5
R_2	2.6	7.8	3
R_3	0.5	1.7	
R_4	2.1		2

Now it's just a matter of using Ohm's Law to fill out the rest of the table. The complete solution is on the next slide.

Problem Solving with Kirchhoff's Rules

Results

Resistor	Current (A)	Voltage (V)	Resistance (Ω)
R_1	0.5	2.5	5
R_2	2.6	7.8	3
R_3	0.5	1.7	3.4
R_4	2.1	4.2	2

Problem Solving with Kirchhoff's Rules

Find the unknowns in the following circuit. You can remove each box to check your work. The complete solution is shown on the next slide.

$$R_3 = 2 \Omega$$

$$I_3 = 10 \text{ A}$$

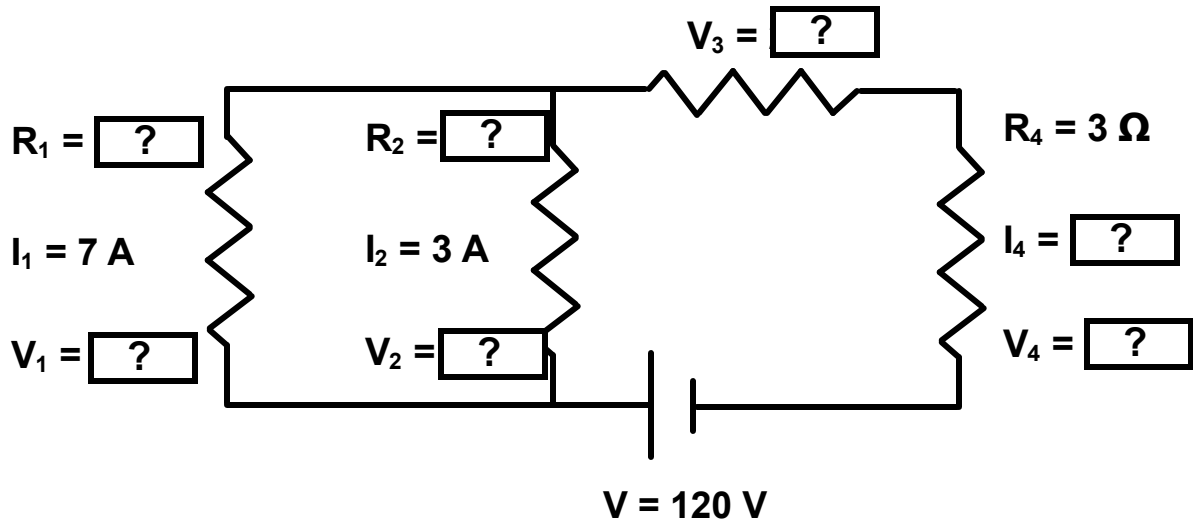

Hint: You don't need Kirchhoff's rules - just circuit knowledge and Ohm's Law.

Problem Solving with Kirchhoff's Rules

The found values are shown in light blue.

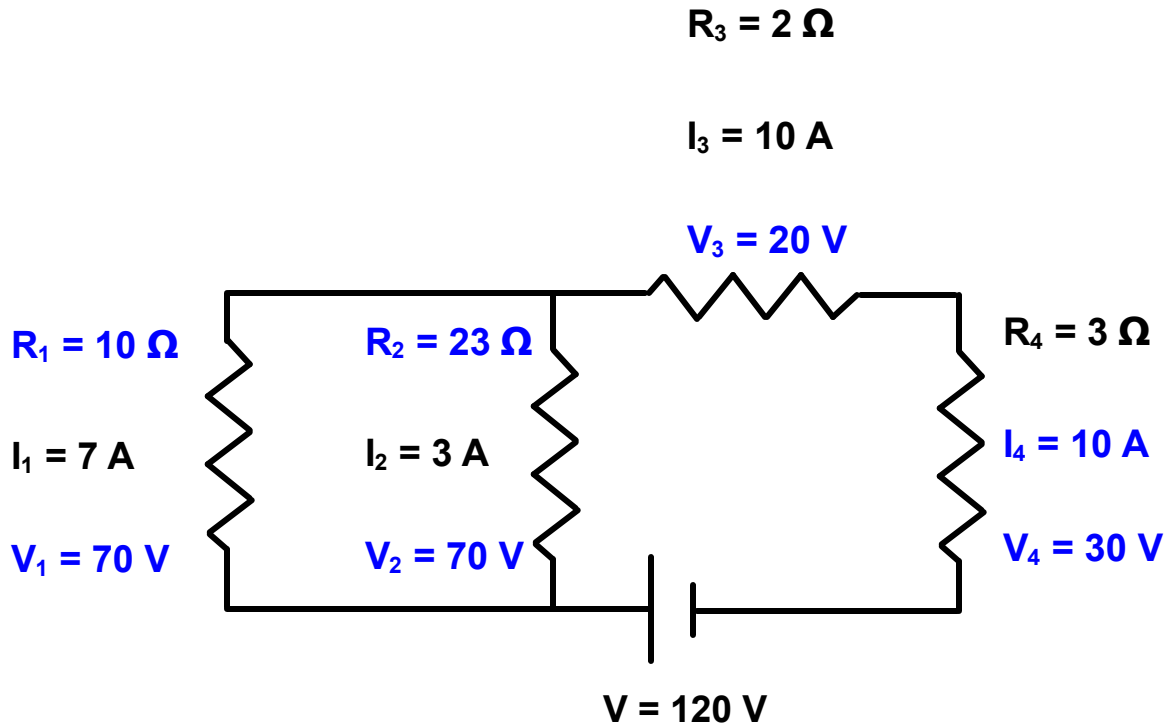

Capacitors

[Return to
Table of
Contents](#)

Parallel Plate Capacitors

A parallel plate capacitor is composed of two conducting plates that are separated by a small distance.

The capacitor is charged by a battery so that equal and opposite charges reside on each plate. A dielectric (insulator) between the plates increases the amount of charge that can be stored for a given applied potential.

The capacitor stores energy in the Electric Field created by the difference in potential between the plates.

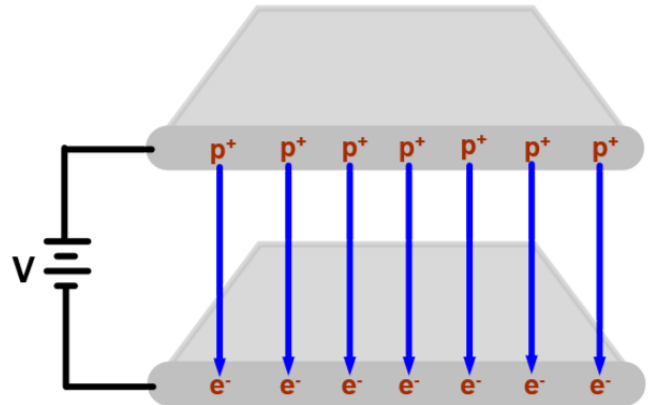

Capacitor

Consider a circuit with a battery (V), parallel plate capacitor (C), switch (S), and light bulb (L).

The battery has a potential difference of V , and the Capacitor has zero potential difference between its plates - it is electrically neutral.

The light bulb is not lit - no current is flowing.

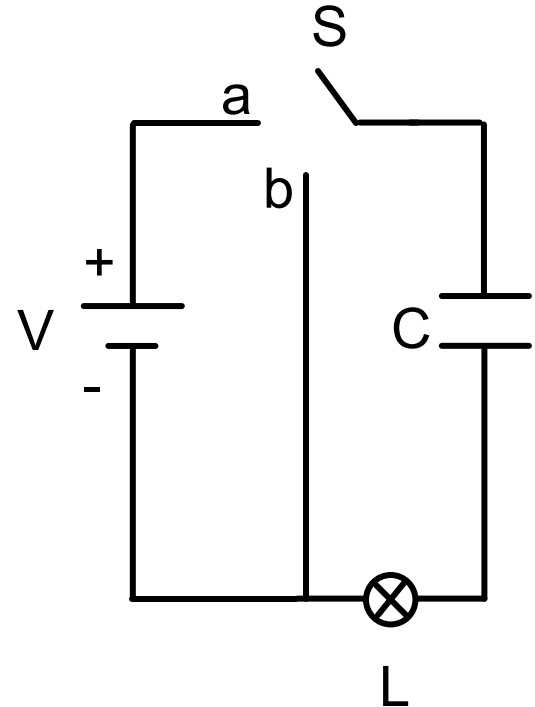

Charging a Capacitor

Close the switch to position a. Electrons from the capacitor's top plate are attracted by the positive terminal of the battery. The charges move through the battery and are deposited on the bottom plate of the capacitor.

Conventional current is defined as the flow of positive charge - so its direction is clockwise - opposite the electron flow.

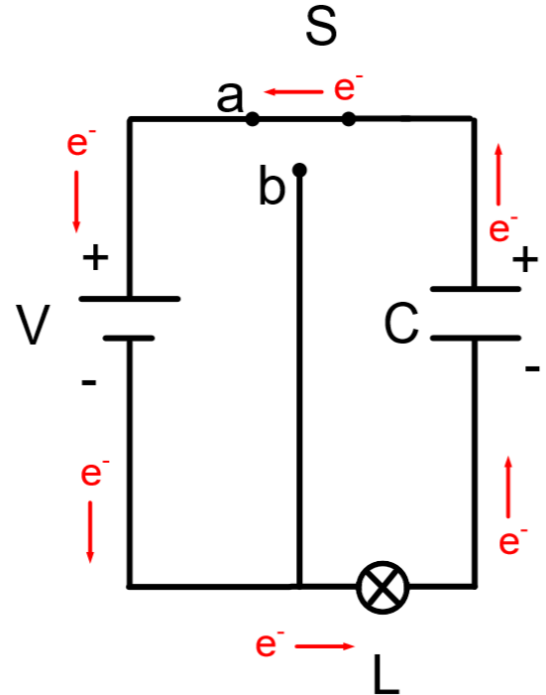

Charging a Capacitor

Every electron that moves to the bottom plate leaves a positive ion behind, charging the bottom negative, and the top, positive.

What happens to the brightness of the light bulb after the switch is closed?

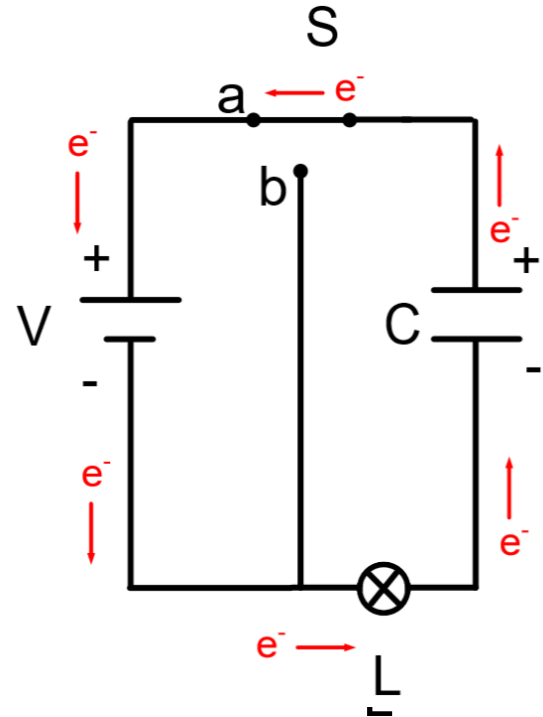

Charging a Capacitor

When the switch is closed, the maximum amount of current is flowing, and the light bulb is at its brightest.

As the plates charge, the potential difference between them increases and opposes the battery's potential difference. The current starts decreasing, and is zero when the two potentials are equal in magnitude.

The light bulb gets dimmer until the current stops and the light bulb goes out. The charge on each plate is now at a maximum.

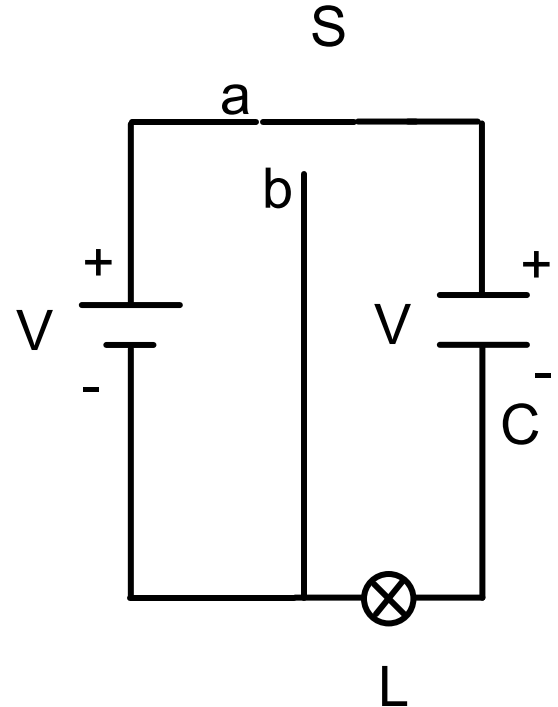

40 A circuit is composed of a battery, light bulb, capacitor and a switch. The switch is closed. When is the light bulb the brightest?

- A The light bulb does not light at all because of the capacitor.
- B It is the same brightness as long as the switch is closed.
- C When the switch is closed.
- D After the switch has been closed a long time.
- I need help

41 When a capacitor is fully charged, what is the relationship of its electric potential to the battery?

- A It has the same magnitude but is in the opposite direction.
- B It has the same magnitude but is in the same direction.
- C It has a smaller magnitude but is in the opposite direction.
- D It has a smaller magnitude but is in the same direction.
- I need help

42 What is the status of the current in a battery-capacitor circuit after the capacitor is fully charged?

- A The current is half the maximum value and in the same direction as the original charging current.
- B The current is at a maximum and in the opposite direction as the original charging current.
- C The current is at a maximum and in the same direction as the original charging current.
- D There is zero current.
- I need help

Discharging a Capacitor

The capacitor is now fully charged to a voltage, V . The switch is moved to position b , removing the battery from the circuit.

Electrons start flowing - but this time in a clockwise direction. Conventional current flows in a counter-clockwise direction.

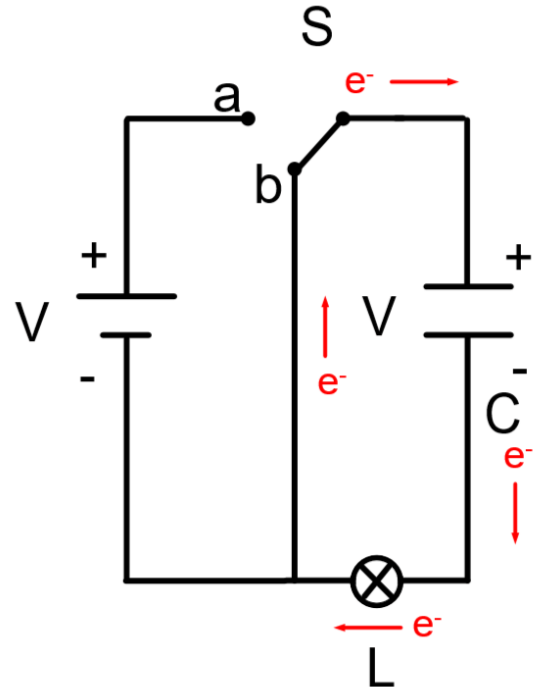

Discharging a Capacitor

The potential difference decreases as the capacitor is discharged. Unlike a battery that maintains its potential by chemical reactions changing chemical energy into electrical energy.

What happens to the light bulb?

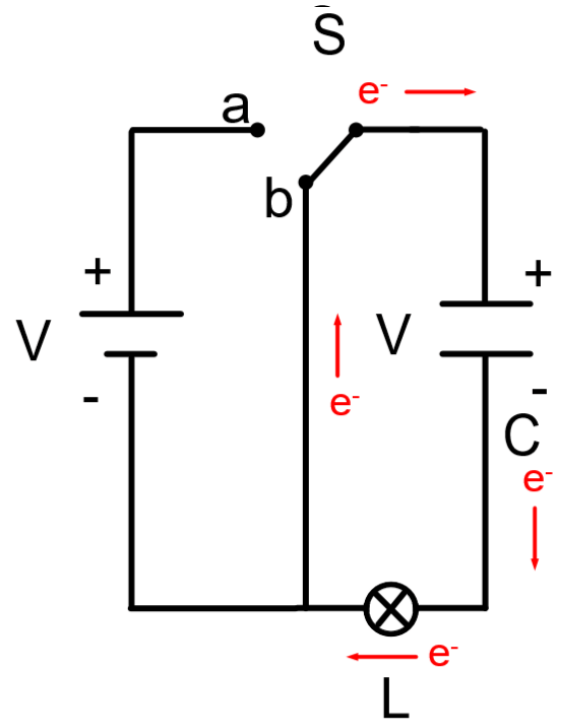

Discharging a Capacitor

As the potential difference decreases to zero, the current decreases (Ohm's Law) until no current flows. The capacitor is now fully discharged.

The light bulb gets dimmer and then turns off.

The resistance of the light bulb is also decreasing as it cools off, but it still has a finite value, so when $V = 0$, then $I = 0$.

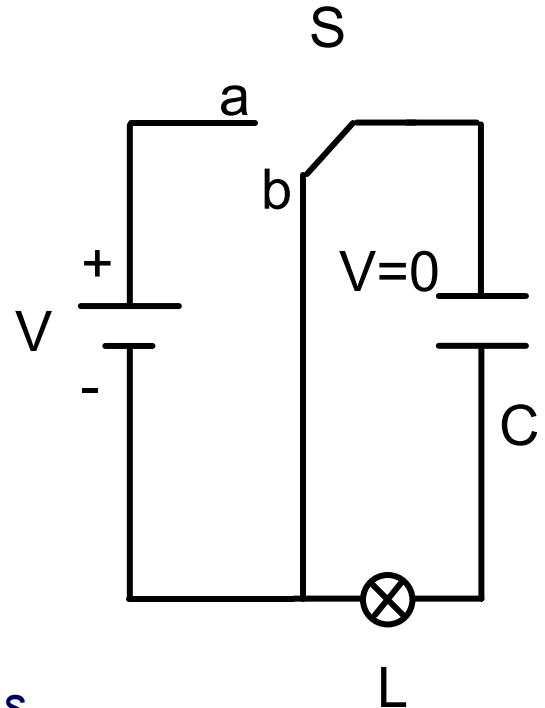

43 The capacitor in the below circuit was fully charged by the battery with the switch in position a. The switch is moved to position b. In what direction does the discharging current flow?

- A Clockwise
- B Counter-clockwise
- C There is no current flow.
- D Clockwise, then counter-clockwise after a period of time.
- I need help

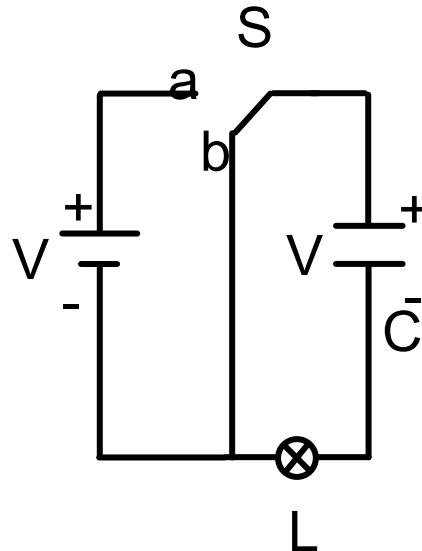

44 In which of the following circuits will the capacitor store charge if the battery is disconnected? **Select two answers.**

A

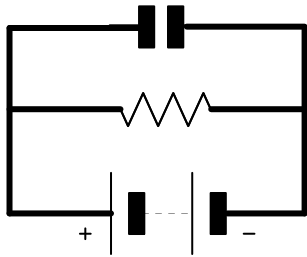

B

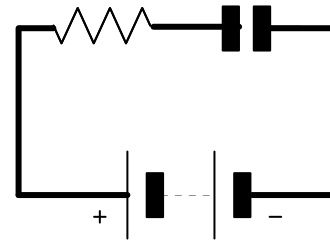

C

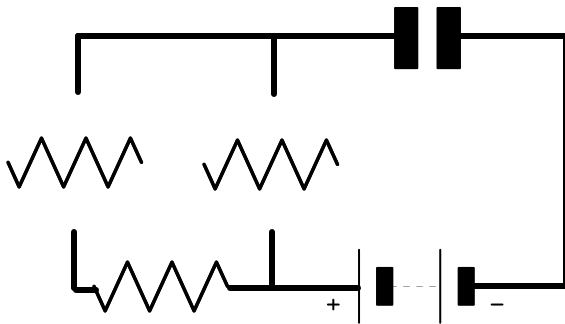

D

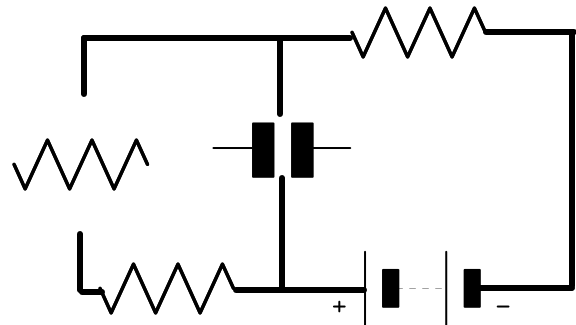

I need help

Equivalent Capacitance

Circuits with multiple capacitors can be redrawn as if there were only a single capacitor and battery - just like we've already done with circuits with resistors.

By reducing the circuit this way, the circuit becomes easier to study.

This process is called finding the equivalent Capacitance for capacitors in series (C_S) and parallel (C_P).

Parallel Circuits: Equivalent Capacitance

What is the voltage across each capacitor?

What is the charge on each capacitor?

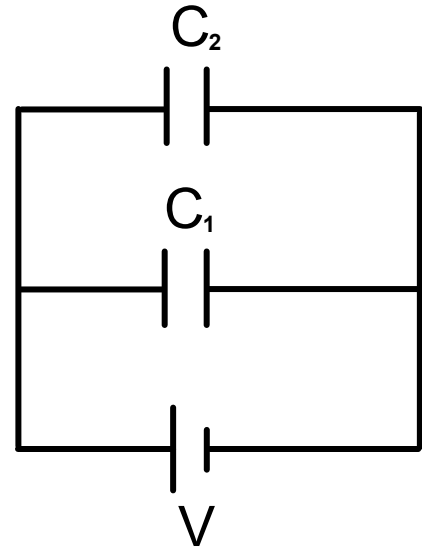

Parallel Circuits: Equivalent Capacitance

The voltage across each capacitor is the same.

$$V = V_1 = V_2$$

The total charge is the sum of the charge on all the capacitors.

$$Q = Q_1 + Q_2$$

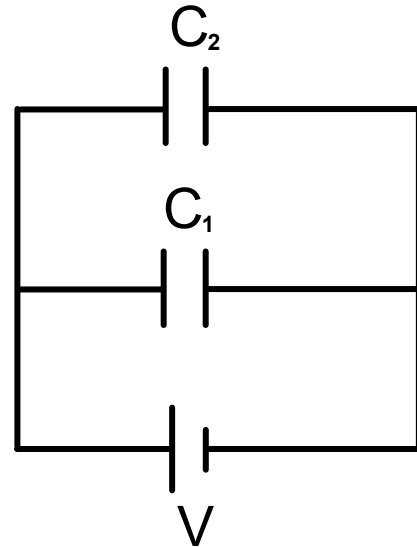

Parallel Circuits: Equivalent Capacitance

Since $V = V_1 = V_2$, $Q = Q_1 + Q_2$ and $Q = CV$

$$CV = C_1V_1 + C_2V_2$$

Replace V_1 and V_2 with V .

$$CV = C_1V + C_2V$$

Divide both sides by V .

$$C = C_1 + C_2$$

For capacitors in parallel $C_P = \sum C_i$

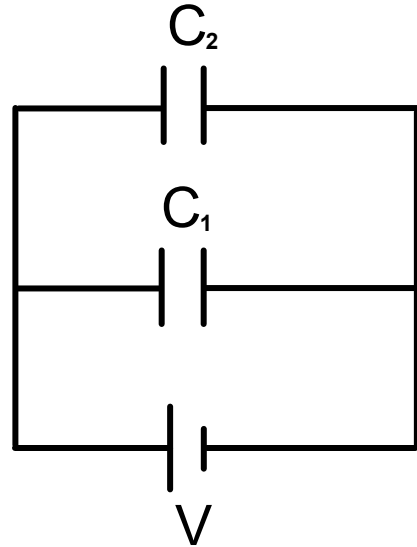

Series Circuits: Equivalent Capacitance

The sum of the voltage drops across each of the capacitors in a series circuit equals the voltage of the battery.

$$V = V_1 + V_2$$

The charge on each capacitor is the same.

$$Q = Q_1 = Q_2$$

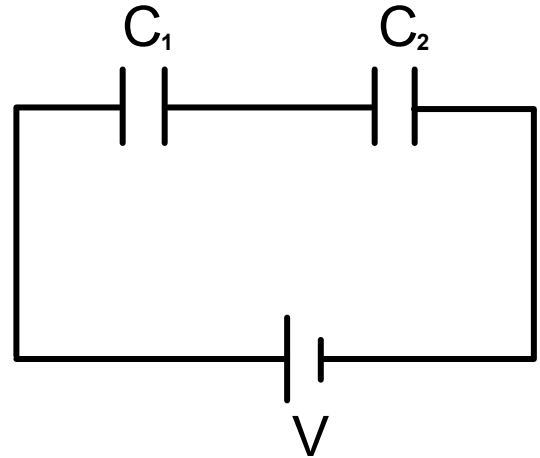

Series Circuits: Equivalent Capacitance

Since $V = V_1 + V_2$, $Q = Q_1 = Q_2$

and $V = Q/C$

$$Q/C = Q_1/C_1 + Q_2/C_2$$

Replace Q_1 and Q_2 with Q .

$$Q/C = Q/C_1 + Q/C_2$$

Divide both sides by Q .

$$1/C = 1/C_1 + 1/C_2$$

So, for capacitors in series $1/C_s = \sum 1/C_i$

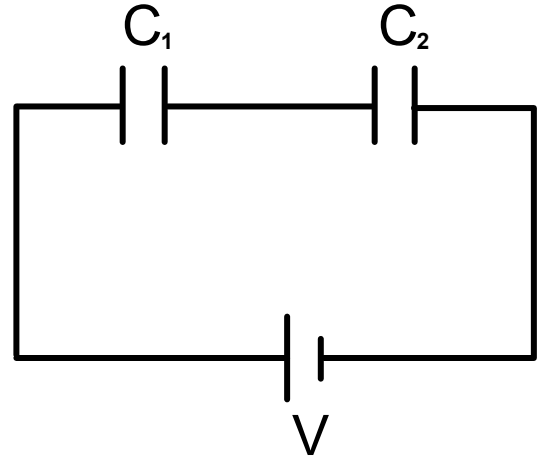

Equivalent Capacitance

Finding equivalent capacitance is like finding equivalent resistance, only reversed.

Capacitors in series are added like resistors in parallel.

$$\frac{1}{C_S} = \sum \frac{1}{C_i} \qquad \frac{1}{C_P} = \sum \frac{1}{R_i}$$

Capacitors in parallel are added like resistors in series.

$$C_P = \sum C_i \qquad R_S = \sum R_i$$

45 What is the equivalent capacitance (in mF) if C_1 is 4mF and C_2 is 6mF?

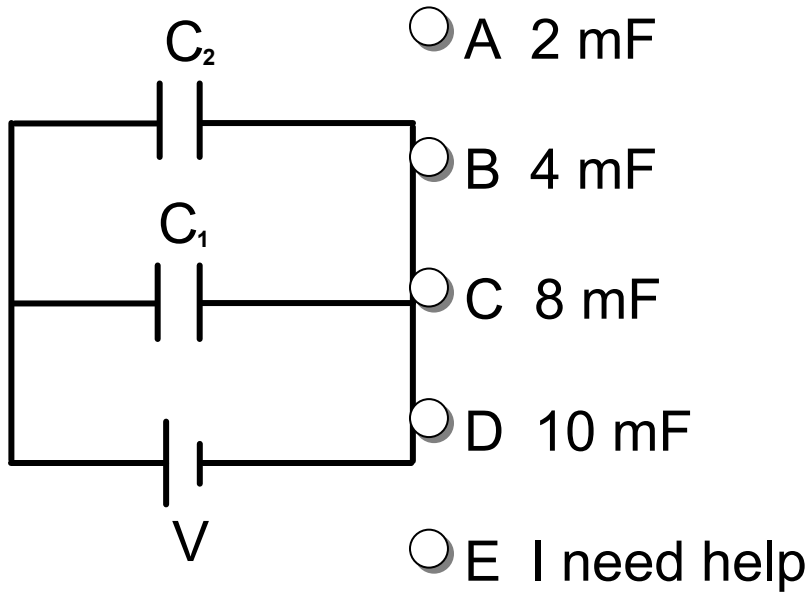

46 What is the equivalent capacitance (in mF) if C_1 is 4mF and C_2 is 6mF?

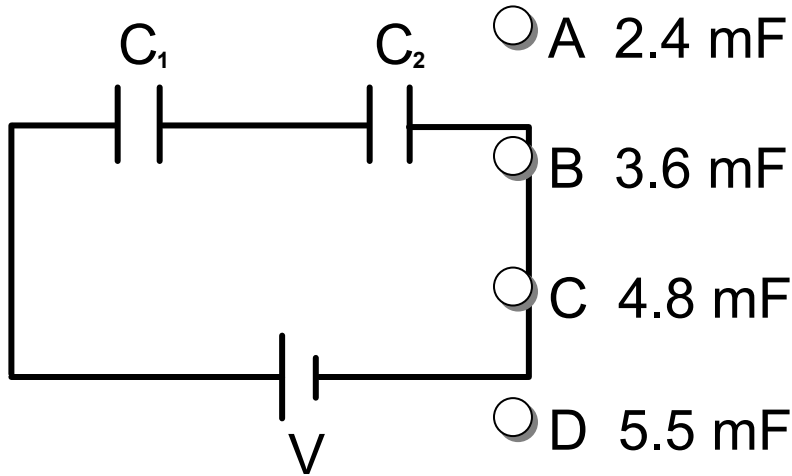

- A 2.4 mF
- B 3.6 mF
- C 4.8 mF
- D 5.5 mF
- E I need help

47 What is the equivalent capacitance (in mF) if C_1 is 5mF and C_2 is 11mF?

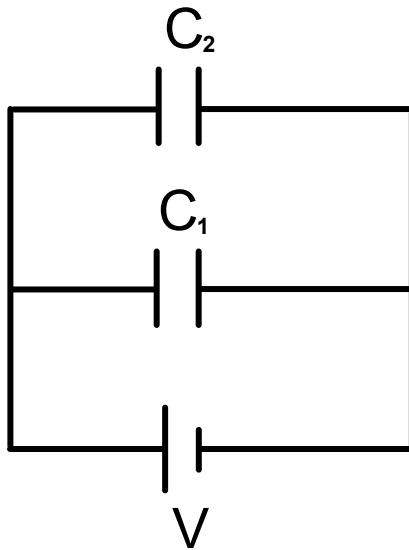

- 5 mF
- 12 mF
- 16 mF
- 20 mF
- I need help

48 What is the equivalent capacitance (in mF) if C_1 is 9 mF and C_2 is 3 mF?

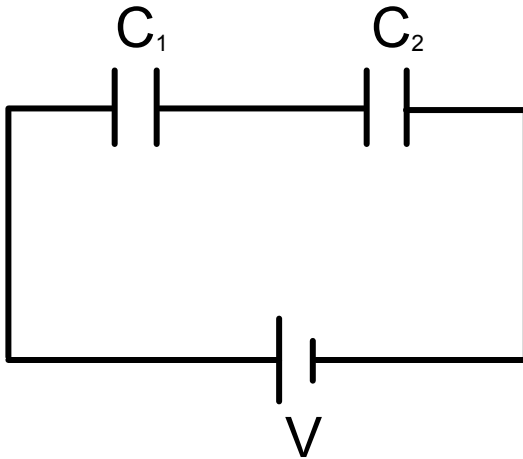

- 1.15 mF
- 2.25 mF
- 3.05 m F
- 4.50 mF
- I need help

RC Circuits

[Return to
Table of
Contents](#)

RC Circuits

A resistor-capacitor (RC) circuit is a circuit composed of resistors and capacitors that are connected to a voltage source.

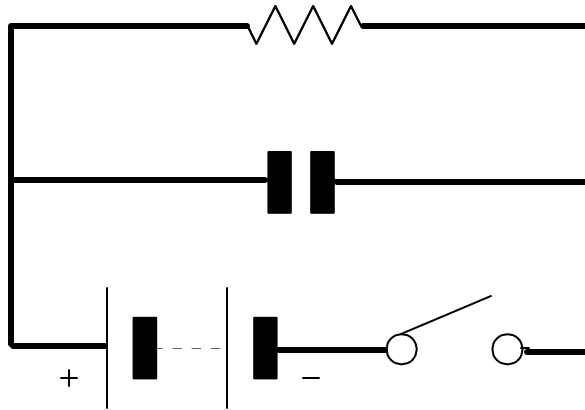

RC Circuits

When the switch is open, there is no current in the top branch with the capacitor and this circuit is the battery and two light bulbs, each with resistance R , in series. The current through the battery is $V/2R$.

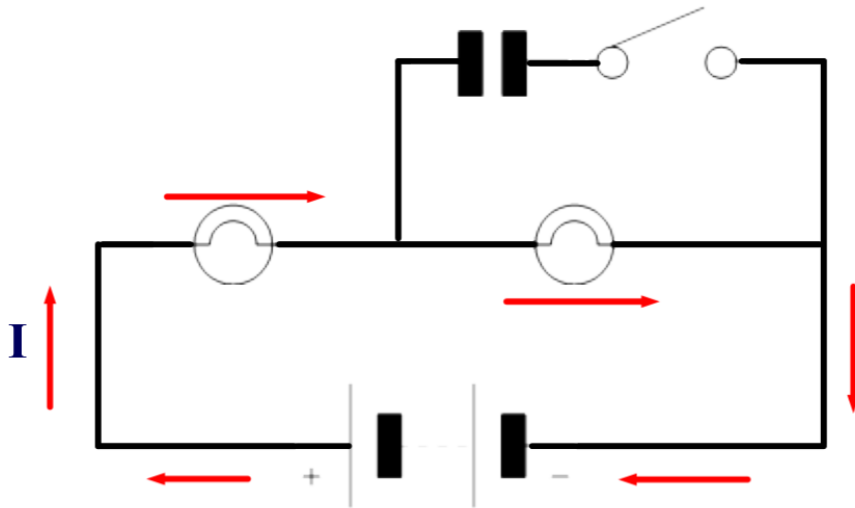

We've switched to using the direction of conventional current flow.

RC Circuits

Close the switch. Immediately after it is closed, there is no resistance in the branch with the capacitor. All of the current goes through that branch and bypasses the second light bulb. The current through the battery increases and is V/R .

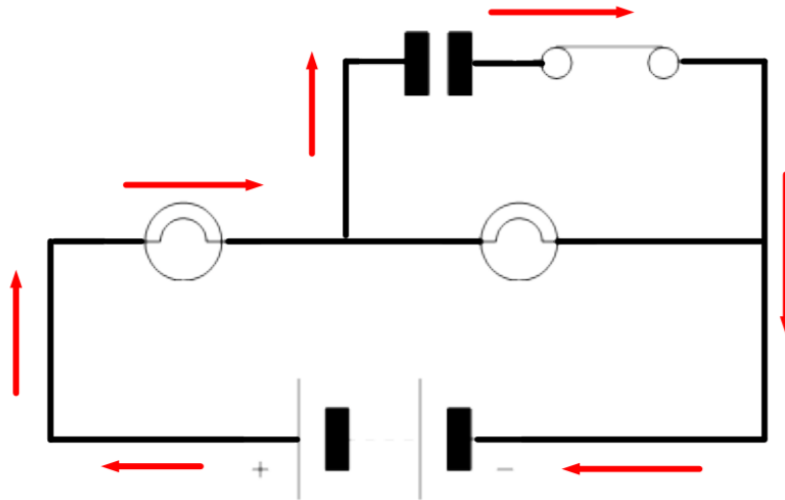

RC Circuits

The current increases in the first light bulb, so it gets brighter.
There is no current in the second light bulb, so it goes out.

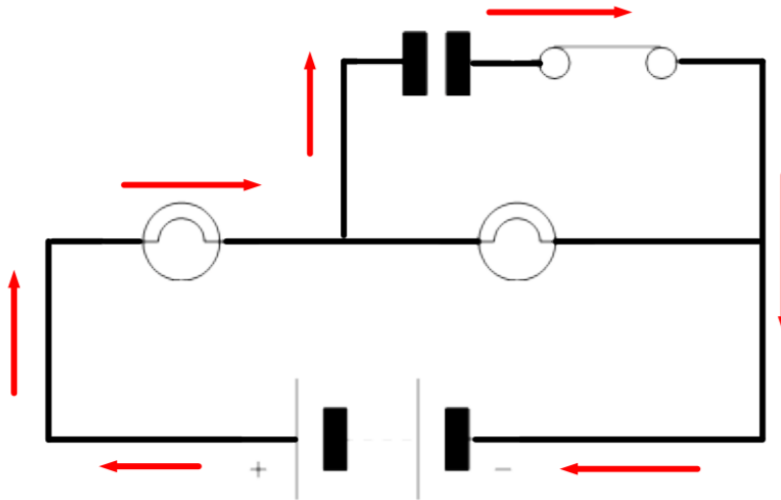

RC Circuits

A long time after the switch is closed, the capacitor is fully charged and there is no more current in the top branch. The rest of the circuit behaves as if the capacitor was disconnected. Therefore the current through the battery is back to $V/2R$.

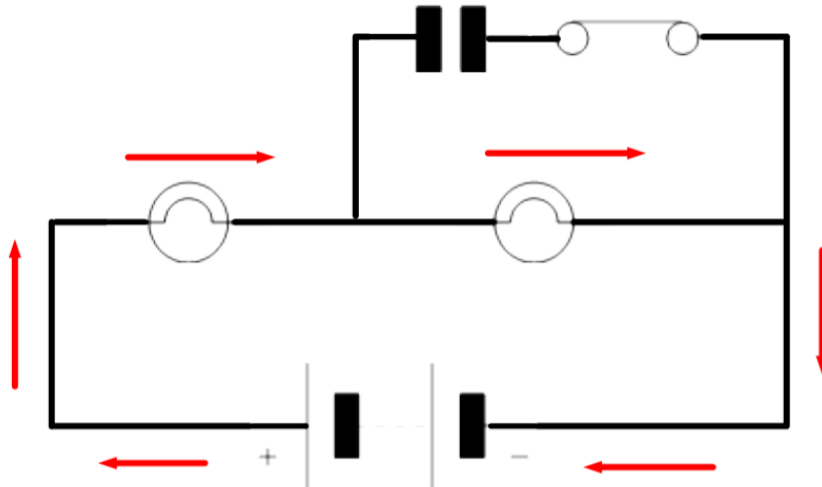

RC Circuits

The first light bulb dims to its original brightness.

The second light bulb starts glowing again and returns to its original brightness.

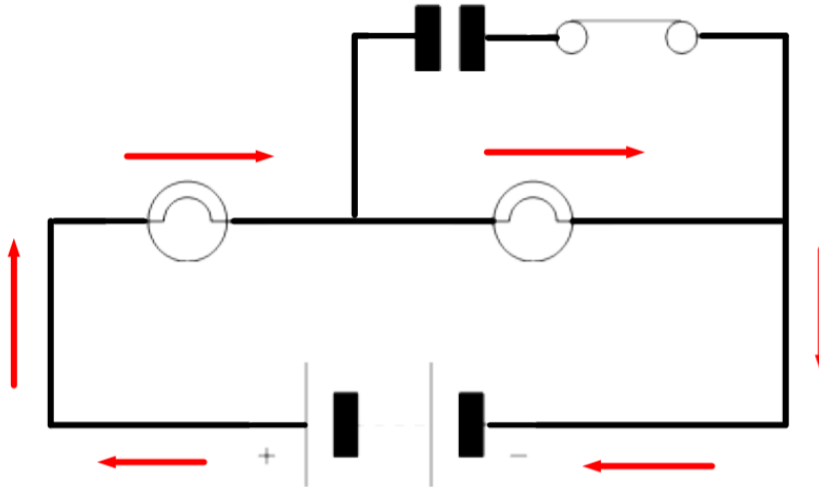

49 Four identical light bulbs are connected in a circuit with a capacitor as shown. The switch is open. Rank the voltage from greatest to least.

- A $V_3 > V_1 > V_2 > V_4$
- B $V_1 = V_2 = V_3 > V_4$
- C $V_4 > V_3 > V_1 = V_2$
- D $V_4 = V_3 > V_1 = V_2$
- E I need help

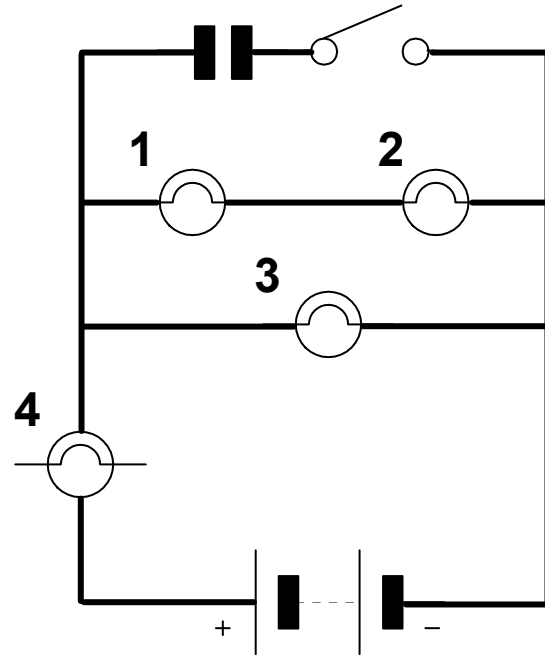

50 Four identical light bulbs are connected in a circuit with a capacitor as shown. Immediately after the switch is closed, rank current from greatest to least.

- A $I_4 = I_3 > I_1 > I_2$
- B $I_1 = I_2 = I_4 > I_3$
- C $I_4 > I_3 > I_1 = I_2$
- D $I_4 > I_3 = I_1 = I_2$
- E I need help

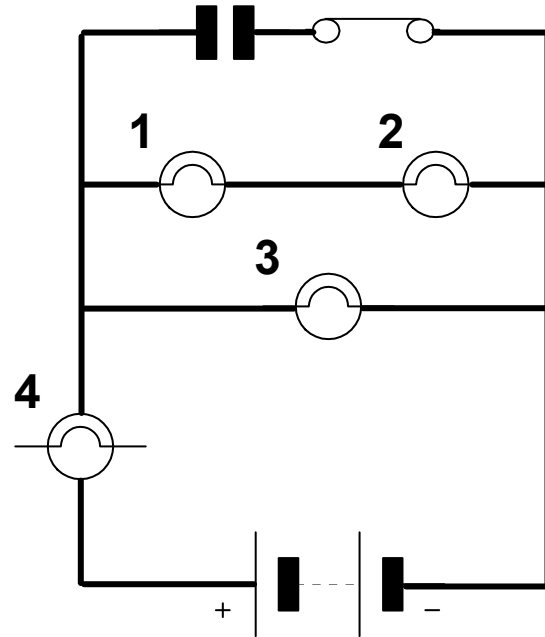

Answer

51 Four identical light bulbs are connected in a circuit with a capacitor as shown. The switch has been closed for a long time. Rank the light bulbs in order of brightness.

- A $4 > 3 > 1 = 2$
- B $1 = 2 = 3 = 4$
- C $1 = 2 > 3 > 4$
- D $3 = 4 > 1 = 2$
- E I need help

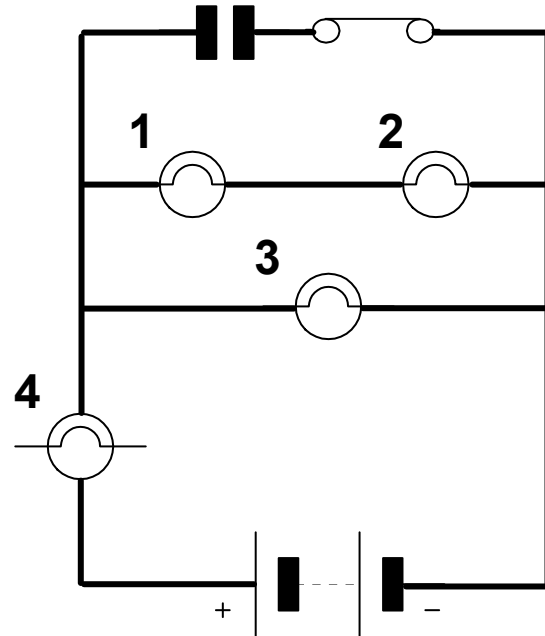

Energy Stored in RC Circuits

Remember from the previous unit that capacitors store potential energy in the electric field between the plates.

The energy stored in a capacitor is given by: $U_c = \frac{QV}{2}$

Using $C = \frac{Q}{V}$, we can also substitute for Q and V and get the

following: $U_c = \frac{1}{2}CV^2$ and $U_c = \frac{Q^2}{2C}$

52 A 3 mF capacitor is connected to a resistor with a resistance of 2Ω and battery with a potential difference of 6V. How much energy, in Joules, is stored in the fully charged capacitor?

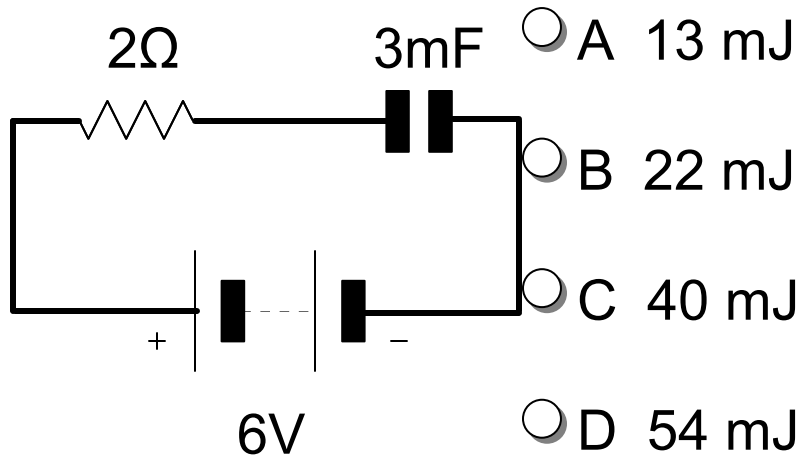

A 13 mJ

B 22 mJ

C 40 mJ

D 54 mJ

E I need help

53 How much energy, in Joules, is stored in the fully charged capacitor shown below, when the switch is open?

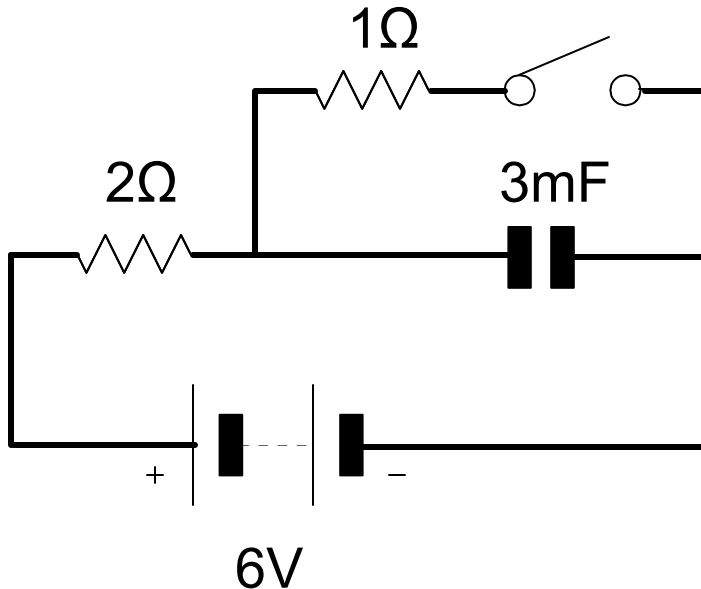

54 mJ

77 mJ

81 mJ

90 mJ

I need help

54 The switch has been closed for a long time in the below circuit. How much energy, in Joules, is stored in the fully charged capacitor?

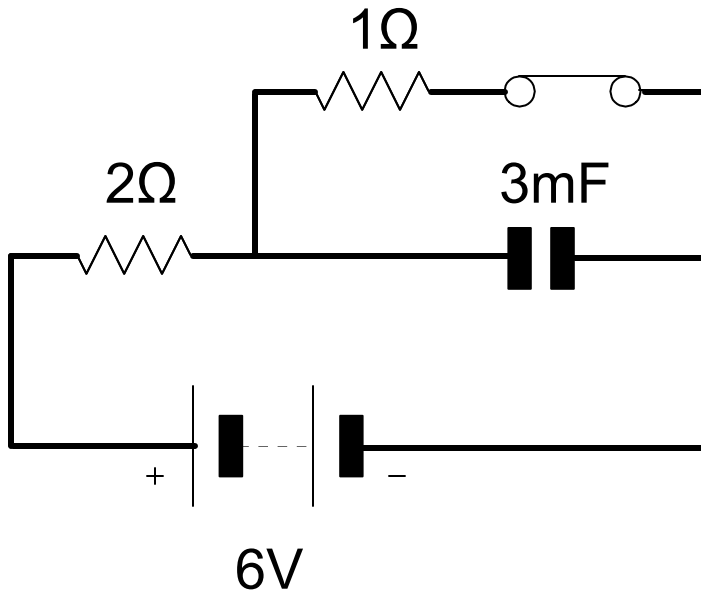

1 mJ

2 mJ

3 mJ

6 mJ

I need help

