Activity 3.3 Making Linear Measurements

Purpose

How thick is one of the hairs on your head? Could it be measured accurately with a standard inch scale? If the smallest increment on an inch scale is $1/16$ inch, then 20 average size human hairs could fit within the space of a $1/16$ inch gap. The required degree of accuracy needed is dependent on the application. If you were to build a home, a standard inch scale is perfect for laying out walls and locating window openings. A dial caliper is a precision measurement tool that is often used in the design and manufacturing of consumer products and is, perhaps, the most common of all the precision measurement tools. Engineers, technicians, scientists, and machinists all use dial calipers to assist the processes of analysis, inspection, engineering design, reverse engineering, and manufacturing.

In this activity you will practice making measurements with a dial caliper.



Equipment

- Engineering notebook
- Dial caliper
- Automoblox vehicle



Procedure

Use dial calipers to make the following measurements. Remember that you can make four different types of measurements with dial calipers. Take careful measurements - you will use your measurements later when you model these parts in 3D solid modeling software.

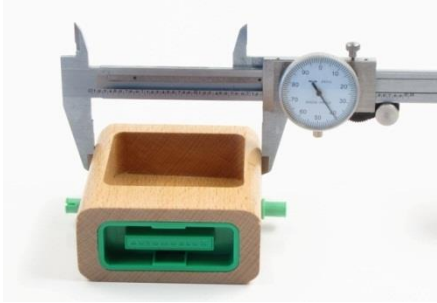

Outside Measure

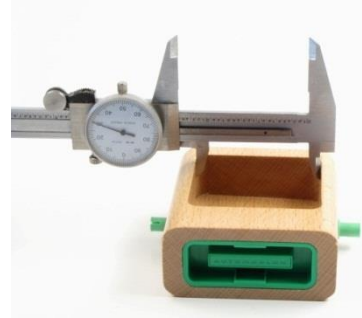

Inside Measurement



Step Measurement



Depth Measurement

1. Using dial calipers, measure and record dimensions of the Passenger Section of the Automoblox vehicle as indicated below.
 - a. Measure the overall dimensions and the depth of the top opening. Be sure to measure the hole depth to the bottom of the hole, not the top of the plastic insert. Record the dimensions on the pictorial below using appropriate significant digits.

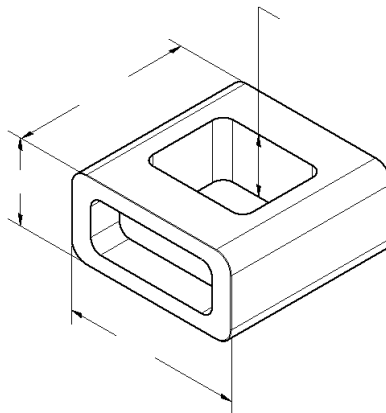

- b. Measure the location and size of the opening on the top of the part. Record your measurements on the top view below to the appropriate number of significant digits.

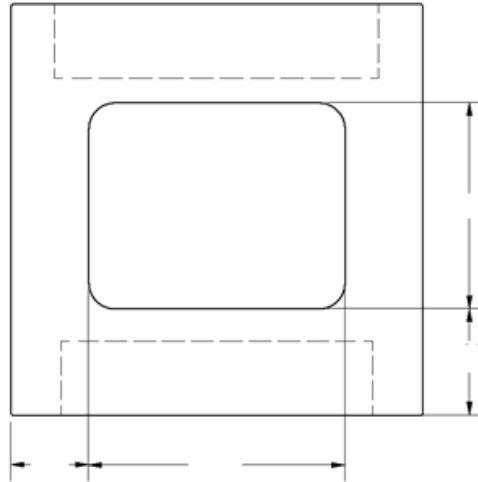

TOP VIEW

- c. Using the dial calipers, *carefully* measure the depths and locations of the holes on the front and back faces of the part where the connector insert is located. Be sure to measure to the bottom of the holes, not the face of the plastic inserts. Record the measurements to the appropriate number of significant digits on the pictorials below.

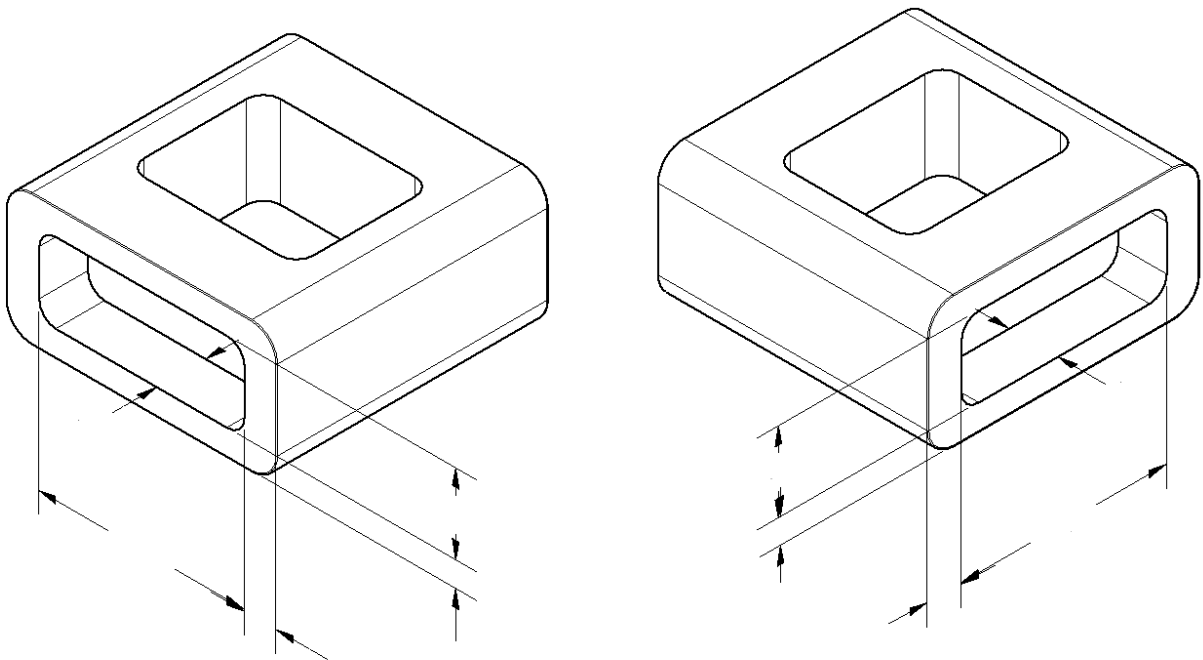

- d. A fillet is an inside radius between two intersecting planes. A round is a rounded exterior blend between two surfaces. Use the dial caliper to estimate the radii of the outside rounds and the fillets at the corner of the holes. You will have to estimate the points of tangency (where the curve transitions into the straight edge). Assume that all the rounds have the same radius and that all the fillets have the same radius. Record the radii below to the appropriate number of significant figures.

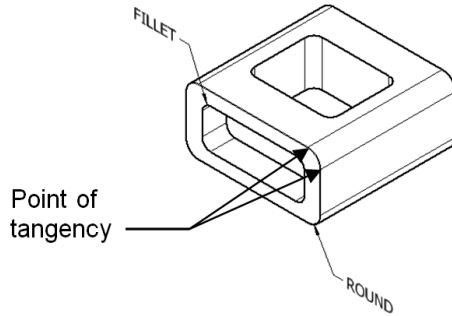

Estimated fillet radius: _____

Estimated round radius: _____

2. Using a dial caliper, Measure and record the missing dimensions of the Automoblox wheel indicated in the views below. Note that you do not need to measure the details of the rim pattern. Record the dimensions using appropriate significant digits. Important: There is a small circular rib on the inside cylindrical surface that fits around the axle pin. Measure the smallest inside diameter of that rib when recording the inside diameter of the wheel.

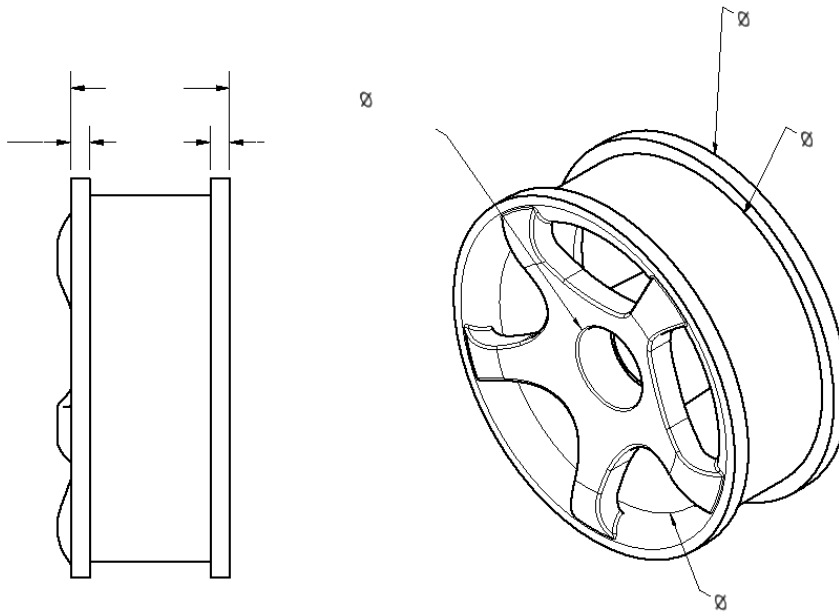

3. Measure and record the dimensions for the connector piece missing on the pictorial below. Next to each recorded measurement, list measurement type (outside diameter/part width, inside diameter/space width, hole/feature depth, and step distance) that you employed to measure the distance.

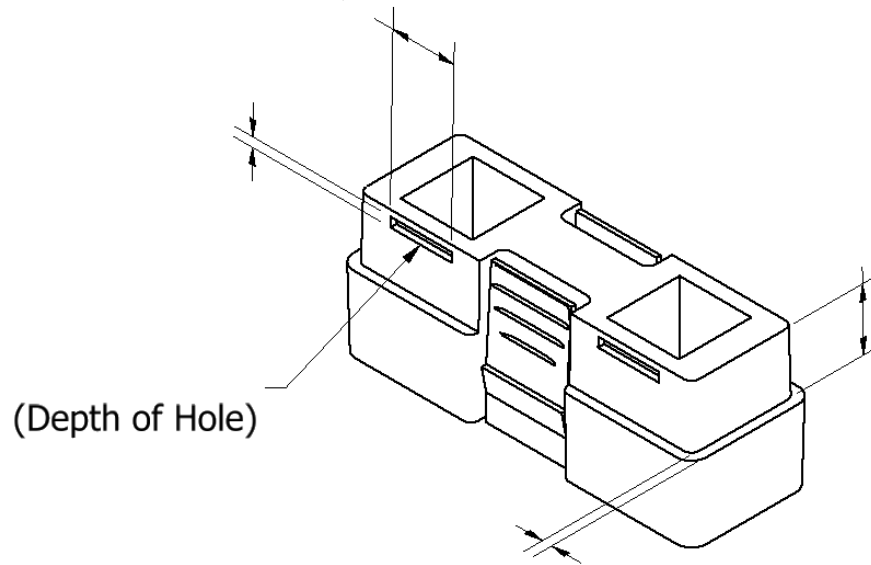

4. Compare your measurements of the Passenger Section with a teammate who measured the same part.
- Are your measurements identical to your teammate's measurements? If no, describe the difference(s).
 - Why would your measurements differ from those of another student who measured the same object?
5. **(Optional)** As a group choose one of the following objects to measure. In your engineering notebook, sketch the object and record dimensions necessary to completely describe the object.
- Graduated cylinder
 - Soda can
 - Coffee cup
 - White board marker
 - Another object as directed by your instructor

